

**WISCONSIN
MODELS W2-880
TJD, THD, TH**

REPAIR MANUAL

W
2
-
8
8
0

T
J
D

T
H
D

T
H



R CORP.

FOREWORD

Good operation and a planned maintenance program as outlined in this manual are vital in obtaining maximum engine performance and long engine life. The instructions on the following pages have been written with this in mind, to give the operator a better understanding of the various problems which may arise, and the manner in which these problems can best be solved or avoided.

The operator is cautioned against the use of any parts, other than genuine Wis-Con Total Power Corp. parts, for replacement or repair. These parts have been engineered and tested for their particular job, and the use of any other parts may result in unsatisfactory performance and short engine life. Wis-Con Total Power Corp. distributors and dealers, because of their close factory relations, can render the best and most efficient service.

THE LIFE OF YOUR ENGINE DEPENDS ON THE CARE IT RECEIVES.

The MODEL, SPECIFICATION and SERIAL NUMBER of your engine must be given when ordering parts. The MODEL and SPECIFICATION number are on the name plate. The SERIAL NUMBER is stamped either on the crankcase or the engine's identification tag.

Copy the MODEL, SPECIFICATION and SERIAL NUMBER in the spaces provided below so that it will be available when ordering parts.

MODEL

SPECIFICATION

SERIAL NUMBER

To insure prompt and accurate service, the following information must also be given:

1. State EXACTLY the quantity of each part and part number.
2. State definitely whether parts are to be shipped by express, freight or parcel post.
3. State the exact mailing address.

IMPORTANT

READ THESE INSTRUCTIONS CAREFULLY

All points of operation and maintenance have been covered as carefully as possible, but if further information is required, send inquiries to the factory for prompt attention.

When writing to the factory, ALWAYS GIVE THE MODEL, SPECIFICATION AND SERIAL NUMBER of the engine referred to.

Starting and Operating New Engines

Careful breaking-in of a new engine will greatly increase its life and result in troublefree operation. A factory test is not sufficient to establish the polished bearing surfaces, which are so necessary to the proper performance and long life of an engine. These can only be obtained by running a new engine carefully and under reduced loads for a short time.

- Be sure the engine is filled to the proper level with a good quality engine oil.
- For proper procedures to follow when breaking-in a new engine, see 'Testing Rebuilt Engine'.

The various bearing surfaces in a new engine have not been glazed, as they will be with continued operation, and it is in this period of "running in" that special care must be exercised, otherwise the highly desired glaze will never be obtained. A new bearing surface that has once been damaged by carelessness will be ruined forever.

IMPORTANT SAFETY NOTICE

Proper repair is important to the safe and reliable operation of an engine. This Repair Manual outlines basic recommended procedures, some of which require special tools, devices or work methods.

Improper repair procedures can be dangerous and could result in injury or death.

READ AND UNDERSTAND ALL SAFETY PRECAUTIONS AND WARNINGS BEFORE PERFORMING REPAIRS ON THIS ENGINE

Warning labels have also been put on the engines to provide instructions and identify specific hazards which, if not heeded, could cause bodily injury or death to you or other persons. These labels identify hazards which may not be apparent to a trained mechanic. There are many potential hazards for an untrained mechanic and there is no way to label the engine against all such hazards. These warnings in the Repair Manual and on the engine are identified by this symbol:



Operations that may result only in engine damage are identified in the Repair Manual by this symbol:



Wis-Con Total Power Corp. cannot anticipate every possible circumstance that might involve a potential hazard; therefore, the warnings in this manual are not all inclusive. If a procedure, tool, device or work method not specifically recommended by Wis-Con Total Power Corp., Industrial Product Division is used, you must satisfy yourself that it is safe for you and others. You should also ensure that the engine will not be damaged or made unsafe by the procedures you choose.

IMPORTANT: The information, specifications and illustrations in this manual are based on information that was available at the time it was published. The specifications, torques, pressures of operation, measurements, adjustments, illustrations and other items can change at any time. These changes can affect the service given to the product. Get the complete and most current information before starting any job. For parts, service, or information, contact Wis-Con Total Power Corp., Memphis, Tennessee.

WARNING

Most sub-systems used in conjunction with Wis-Con Total Power Corp. industrial engines including (but not limited to) radiators, hoses, fans, fuel tanks, fuel lines or other fuel system components, batteries, electrical connections or other electrical components, clutches, transmissions, hydraulic pumps and generators, are not supplied by Wis-Con Total Power Corp. These items are provided by the manufacturer of the end item in which the engine is used.

Some of the dangers associated with servicing such items are generally mentioned in this manual; however, the appropriate handbooks and safety instructions provided by the manufacturer of the end item should always be consulted prior to the undertaking of any work on sub-systems attached to the engine, to avoid any hazards inherent to these sub-systems.

WARNING

Read and observe all individual safety warnings as you use this manual to operate, service or repair your engine.

Always exercise caution whenever working with an engine or any associated system.

Injuries may be caused by lack of care when working with, or near, moving parts, hot parts, pressurized systems, electrical equipment, or fuel systems.

Always wear eye and hearing protection when working on or near engines.

Improper attire such as loose clothing, ties, rings, soft shoes or bare feet could be hazardous and should be avoided when servicing engines.

Use or service of the engine (including the use of modified parts or materials) not in accordance with manufacturer's specifications could damage your engine or cause personal injury.

WARNING

Some equipment and materials used in the overhaul or maintenance of an engine such as machine tools, electrical equipment, compressed air, solvents, gasoline or other fuels may be dangerous and can cause injury. Always observe safety precautions.

Safety Precautions

- Never fill fuel tank while engine is running or hot; avoid the possibility of spilled fuel causing a fire.
- Always refuel slowly to avoid spillage.
- When starting engine, maintain a safe distance from moving parts of equipment.
- Do not start engine with clutch engaged.
- Do not spin hand crank when starting. Keep cranking components clean and free from conditions which might cause the crank jaw to bind and not release properly. Oil periodically to prevent rust.
- Never run engine with governor disconnected, or operate at speeds in excess of 3600 R.P.M. load.
- Do not operate engine in a closed building unless the exhaust is piped outside. This exhaust contains carbon monoxide, a poisonous, odorless and invisible gas, which if breathed causes serious illness and possible death.
- Never make adjustments on machinery while it is connected to the engine, without first removing the ignition cables from the spark plugs. Turning the machinery over by hand during adjusting or cleaning might start the engine and machinery with it, causing serious injury to the operator.
- Precaution is the best insurance against accidents.

Keep this book handy at all times, familiarize yourself with the operating instructions.

CONTENTS

Air Cleaners	10	Ignition Switch	9
Dry Element (Tri-Phase) Air Cleaner	11	Ignition System	8
Dry Type Air Cleaner	11	Illustrations, Engine	
Oil Bath Air Cleaner	10	Cross Section (TJD)	6
Alternator — Flywheel	17	Fan End View (W2-880)	5
Battery Ignition — Distributor	14	Lubrication System (TJD)	7
Breather — Crankcase	11	Power Unit Fan End View (TJD)	4
Carburetor Adjustment	12	Take-off View (TJD)	3
Carburetor Service		Take-off View (W2-880)	5
Walbro Model LMH-33	37	Lubrication	8
Walbro Model LUB	35	Lubrication System	8
Walbro Model WHG-53	39	Magneto Breaker Point Adjustment	12
Zentih Model 68-7	33	Magneto Ignition Spark	12
Clutch Adjustment	19	Magneto Service	
Clutch Power Take-off	19	Fairbanks-Morse (Type FMX2B7E)	42
Clutch Reduction Unit Adjustment	20	Fairbanks-Morse (Type FMX12B71)	43
Compression — Restoring	17	Wico Model XH-2D	41
Cooling	8	Magneto Timing	13
Disassembly and Reassembly	22	Magneto Timing Diagram	13
Accessories	22	Maintenance Section	10
Camshaft	28	Oil — Grade of and Service Classification	9
Camshaft Gear	25	Oil Spray Nozzles	28
Carburetor and Manifold	24	Reduction Gears	20
Connecting Rod and Piston	25	Rotation	8
Crankshaft and Main Bearing Plate	27	Safety Precautions	1
Cylinder Block	27	Safety Switch - High Temperature	17
Cylinder Head	24	Solid State Ignition Distributors	16
Engine Base	25	Spark Plugs	17
Flywheel and Shroud	23	Starting and Operating Instructions	8
Fuel Tank	24	Starting and Operating New Engines	i
Gear Cover	24	Starting Procedure	10
House Panels	22	Stopping Engine	10
Oil Pump	25	Storage of Engine for Winter	20
Piston Ring and Rod Clearance Chart	26	Testing Rebuilt Engine	22
Piston Rings	26	Timing	
Valve Tappets	28	Distributor Timing	14
Valves and Seat Inserts	27	Magneto Timing	13
Distributor and Generator Maintenance	15	Neon Lamp Timing	15
Electric Wiring Circuits	15	Troubles — Causes and Remedies	20
Electrical Wiring Diagrams	16	Backfiring Through Carburetor	22
Firing Order	14	Compression	21
Flywheel Alternator with Solid State Regulation	30	Ignition	21
Fuel	9	Knocking	22
Fuel Filter	11	Missing	21
Fuel Pump & Priming	9	Overheating	22
Fuel Pump Service	29	Starting Difficulties - Fuel Mixture	21
Gear Train — Timing Marks (Fig. 36)	25	Stops	21
General Information and Design	8	Surging or Galloping	21
Governor Adjustment	18	Valves — Grinding	27
Governor Operation	18	Valve Tappet Adjustment	28
Horsepower	8	Warm-Up Period — Overspeeding	10

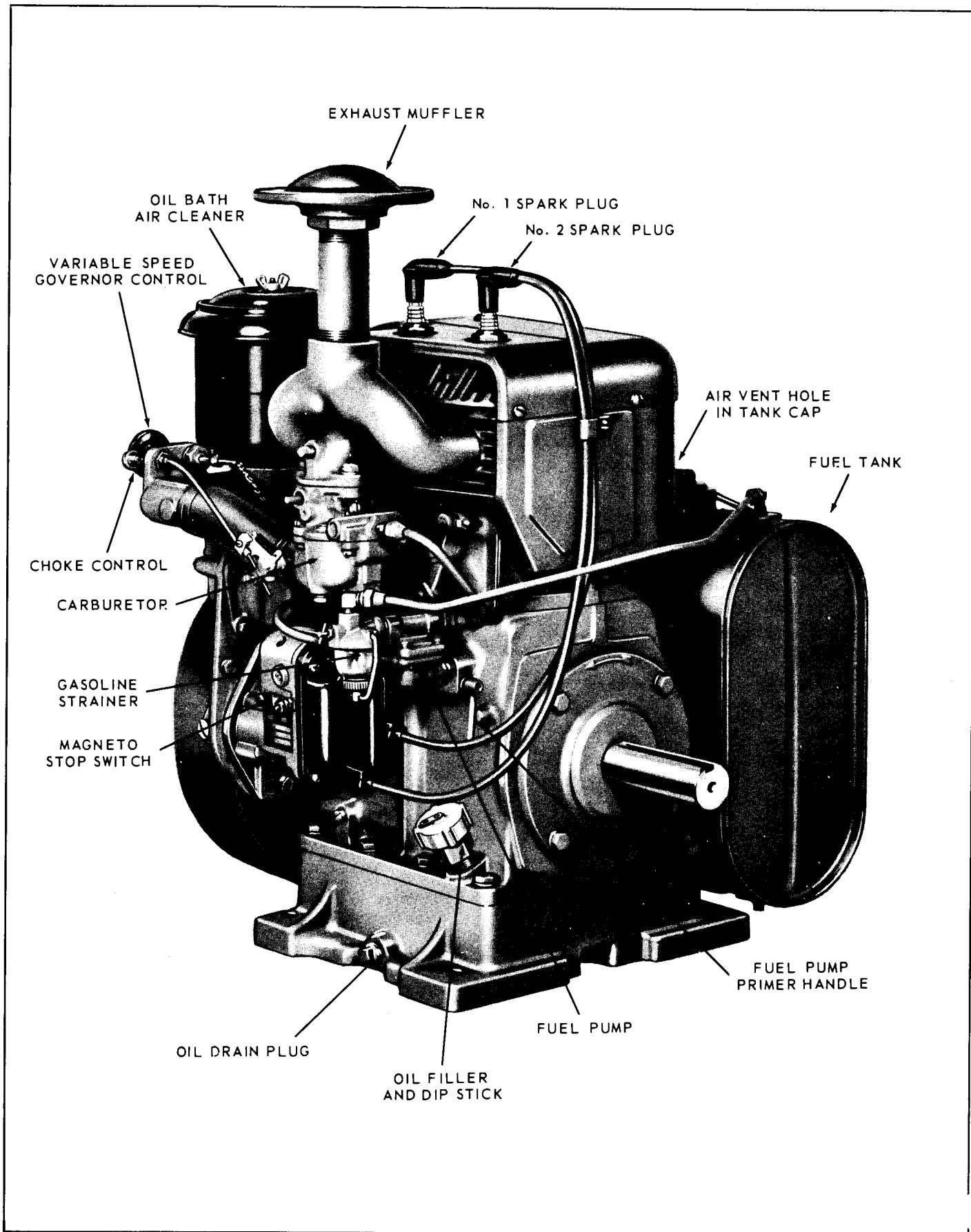

Fig. 1

TAKE-OFF (Side Mount Tank) VIEW OF ENGINE MODEL TJD

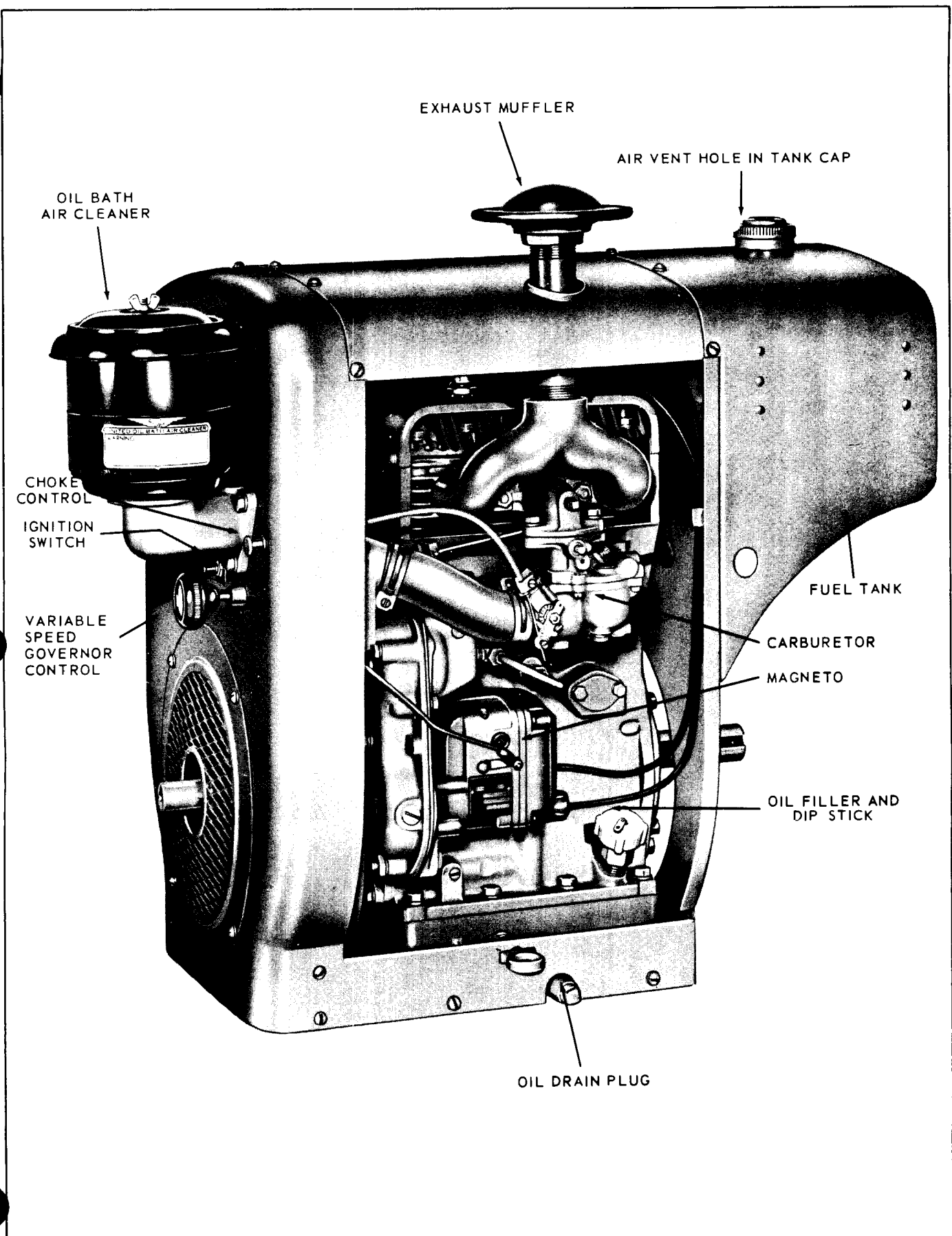

Fig. 2
POWER UNIT FAN END VIEW OF ENGINE MODEL TJD

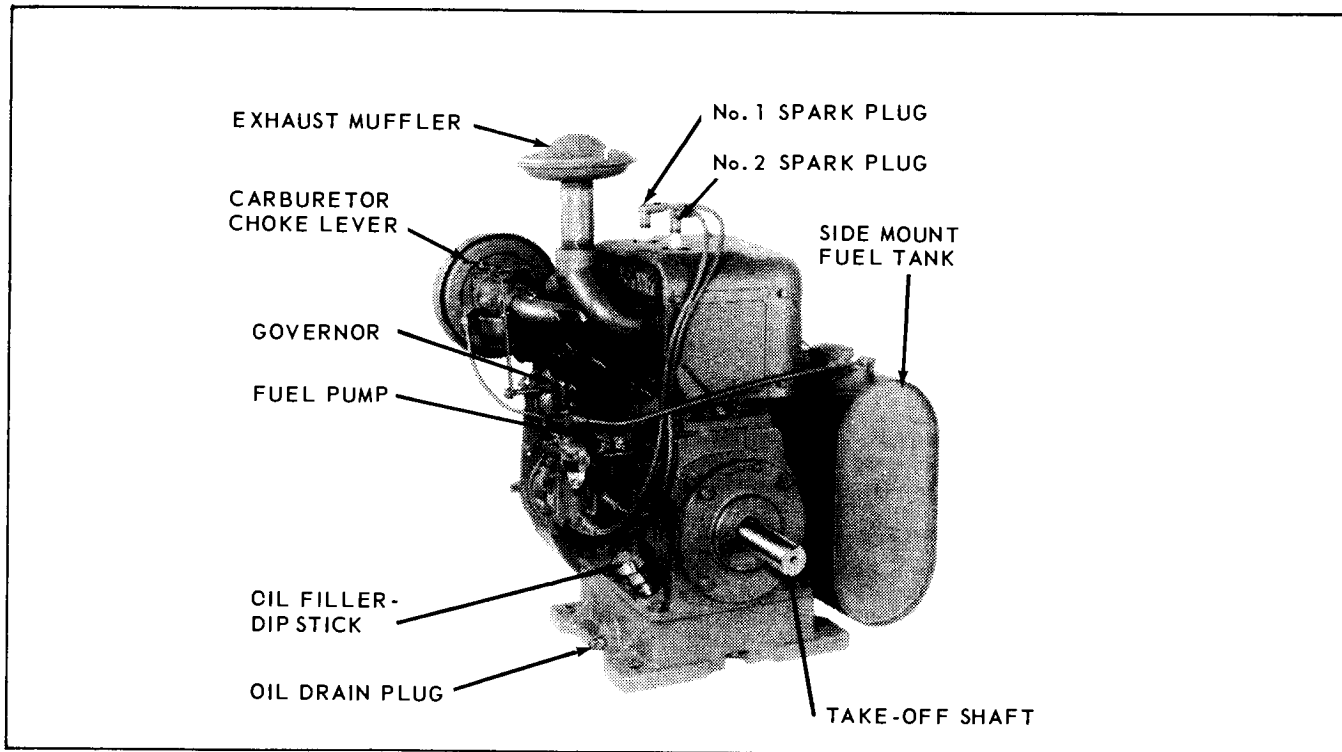

Fig. 2A

TAKE-OFF (Side Mount Tank) VIEW OF ENGINE
MODEL W2-880

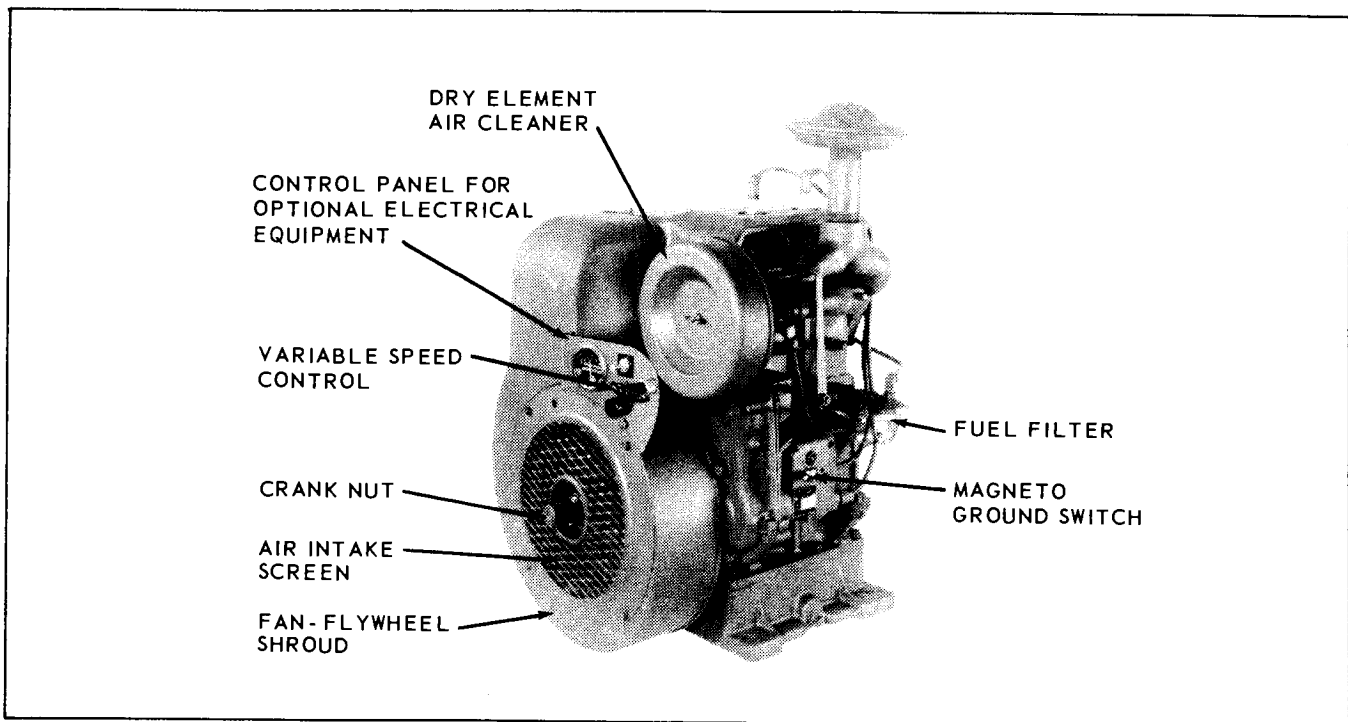

Fig. 2B

POWER UNIT FAN END VIEW OF ENGINE MODEL W2-880

CROSS SECTION OF ENGINE MODEL TJD

Fig. 3

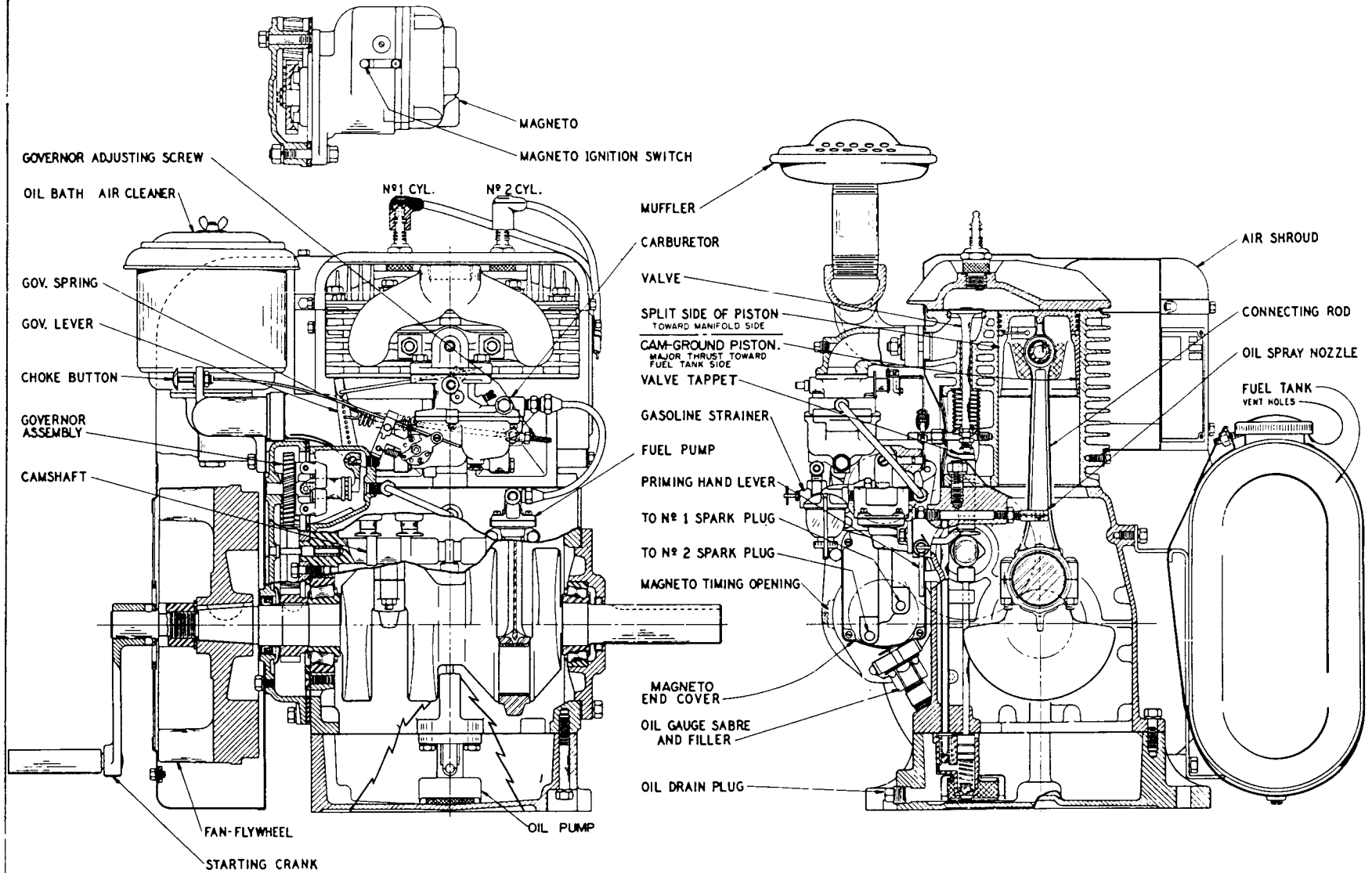
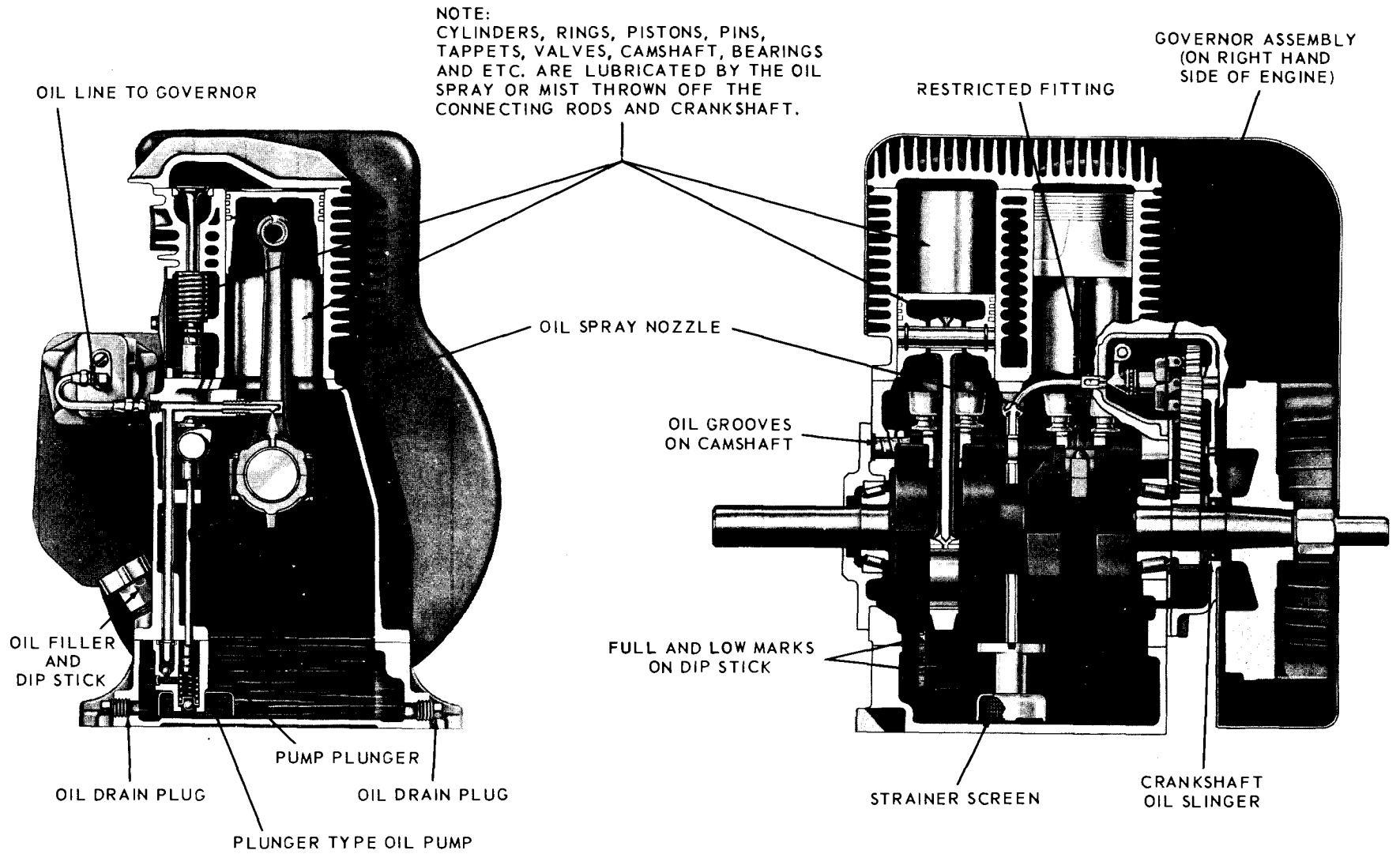

Fig. 4



GENERAL INFORMATION AND DESIGN

Wisconsin engines are of the **four cycle type**, in which each of the four operations of **intake, compression, expansion and exhaust** requires a complete stroke. This gives one power stroke per cylinder for each two revolutions of the crankshaft.

COOLING

Cooling is accomplished by a flow of air, circulated over the cylinders and heads of the engine, by a combination fan-flywheel encased in a sheet metal shroud. The air is divided and directed by ducts and baffle plates to insure uniform cooling of all parts.

Never operate an engine with any part of the shrouding removed – this will retard air cooling.

Keep the cylinder and head fins free from dirt and chaff. Improper circulation of cooling air will cause engine to overheat.

CARBURETOR

The proper combustible mixture of gasoline and air is furnished by a balanced carburetor, giving correct fuel to air ratios for all speeds and loads.

IGNITION SYSTEM

The spark for ignition of the fuel mixture is furnished by a high tension magneto driven off the timing gears at crankshaft speed. The magneto is fitted with an impulse coupling, which makes possible a powerful spark for easy starting. Also, the impulse coupling automatically retards the spark for starting, thus eliminating possible kick back from engine while cranking.

Battery ignition (12 volt) distributor, is furnished in place of magneto on engines equipped with flywheel alternator or generator.

LUBRICATION SYSTEM (Fig. 4)

A plunger type pump supplies oil to a spray nozzle which directs oil streams against the connecting rods. Part of the oil from the spray nozzle enters the rod bearings and the balance of oil forms a spray or mist which provides ample lubrication for all internal friction surfaces of the engine.

An external oil line from the oil header in the crankcase lubricates the governor and gear train.

GOVERNOR

A governor of the centrifugal flyball type maintains the engine speed by varying the throttle opening to suit the load imposed upon the engine. These engines are equipped with either a **fixed speed** governor, a **variable speed control** to regulate the governed speed of the engine, or an **idle control**.

ROTATION

The rotation of the crankshaft is clockwise when viewing the flywheel or cranking end of the engine.

HORSEPOWER

RPM	Models			
	TH	THD	TJD	W2-880
1600	10.0	10.0	10.0	10.4
1800	11.7	11.7	11.7	12.0
2000	13.1	13.1	13.1	13.3
2200	14.2	14.2	14.2	14.8
2400	15.2	15.2	15.2	16.0
2600	16.4	16.4	16.4	17.2
2800		17.0	17.0	18.1
3000		17.5	17.5	18.7
3200		18.0	18.0	19.4
3400		17.9	18.2	19.8
3600		16.8	18.2	20.0

This gives **counter-clockwise rotation** when viewing the power take-off end of the crankshaft. The flywheel end of the engine is designated the **front end**, and the power take-off end, the **rear end** of the engine.

Horsepower specified in the accompanying chart is for an atmospheric temperature of 60° Fahrenheit at sea level and at a Barometric pressure of 29.92 inches of mercury.

For each inch lower the Barometric pressure drops, there will be a loss in horsepower of 3½%.

For each 10° temperature rise there will be a reduction in horsepower of 1%.

For each 1000 ft. altitude above sea level there will be a reduction in horsepower of 3½%.

The friction in new engines cannot be reduced to the ultimate minimum during the regular block test, but engines are guaranteed to develop at least 85 per cent of maximum power when shipped from the factory. The power will increase as friction is reduced during the first few days of operation. The engine will develop at least 95% of maximum horsepower when friction is reduced to a minimum.

For continuous operation, allow 20% of horsepower shown as a safety factor.

STARTING AND OPERATING INSTRUCTIONS

Some of these engines are enclosed in a sheet metal house, as shown in *Fig. 2*, and are called power units. Others are furnished without a house, as shown in *Fig. 1, Fig. 2A and Fig. 2B*, and are called open engines.

On engines with a house, the side doors should always be removed when operating.

This is necessary for circulating sufficient air for cooling the engine.

LUBRICATION

Before starting a new engine, fill crankcase base with the correct grade of engine oil, as specified in "*Recommended*"

RECOMMENDED LUBRICATING OILS

Season or Temperature	Grade of Oil
Spring, Summer or Autumn +120°F to 40°F	SAE 30
Winter +40°F to 15°F	SAE 20
Below +15°F	SAE10W-30
Use oils classified as Service SE or SF.	

Lubricating Oils" chart. The capacity is **3 1/2 quarts**, indicated by a **FULL** mark on **dip stick**, see Fig. 4. The combination oil dip stick and filler is mounted on the carburetor side of the engine, but can be located on the starting motor side upon request.

For **run-in of new engines**, use same oil as recommended in "*Recommended Lubricating Oils" Chart.*

Use only high-grade highly refined oils, corresponding in body to the S.A.E. (Society of Automotive Engineers) Viscosity numbers listed in "*Recommended Lubricating Oils" Chart.* These will prove economical and assure long engine life.

SERVICE CLASSIFICATION OF OIL

In addition to the S.A.E. Viscosity grades, oils are also classified according to severity of engine service. Use oils classified by the American Petroleum Institute as **Service SE, SF or SG.** This type of oil is for engines performing under unfavorable or severe operating conditions such as: high speeds, constant starting and stopping, operating in extreme high or low temperatures and excessive idling.

Follow summer recommendations in winter if engine is housed in warm building.

Check oil level every 8 hours of operation.

The old oil should be drained and fresh oil added after every 50 hours of operation.

To drain oil; remove drain plug at either side of crankcase base. Oil should be drained while engine is hot, as it will then flow more freely.

FUEL

These engines can be furnished with either a gravity feed tank mounted above the carburetor fuel level, a side mount tank, or tank mounted below the engine. In the latter two cases, a fuel pump is furnished.

The fuel tank should be filled with a **good quality** gasoline free from dirt and water. Some of the poorer grades of gasoline contain gum which will deposit on valve stems, piston rings, and in the various small passages in the carburetor, causing trouble in operating, and in fact might prevent the engine from operating at all.

Use only reputable, well known brands of gasoline of the REGULAR GRADE.

The gasoline should have an octane rating of at least 90. Fuel with a low octane rating will cause detonation, and if operation is continued under this condition, severe damage will result to the engine. The cylinders and pistons will score, head gasket blow out, bearings will be damaged, etc.

Be sure that air vent in fuel tank cap is not plugged with dirt, as this would impede the flow of gasoline.

FUEL PUMP and PRIMING (Fig. 5)

The diaphragm type fuel pump, furnished on engines with side mount or underslung fuel tanks, is actuated by an eccentric on the camshaft, as illustrated in cross section of engine, Fig. 3. For maintenance and repair, refer to fuel pump instructions in rear section of manual.

Hand Primer for hand crank engine is an accessory furnished only upon request, and is a necessary function when starting a new engine for the first time, or when engine has been out of operation for a period of time. Gravity feed and electric start engines do not require hand priming.

When priming, a distinct resistance of the fuel pump diaphragm should be felt when moving the hand lever up and down. If this does not occur, the engine should be turned over one revolution so that the fuel pump drive cam will be rotated from its upper position which prevents movement of the pump rocker arm.

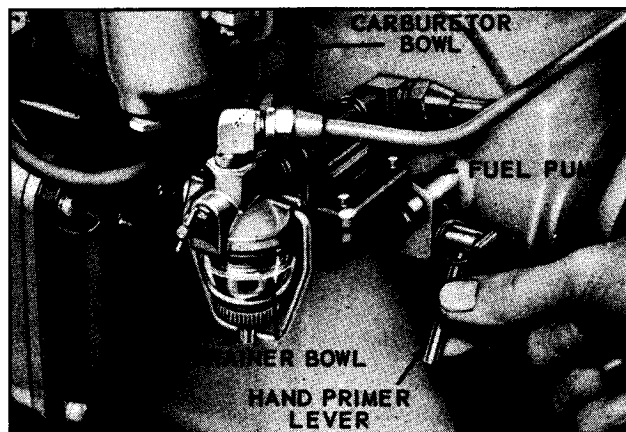

Fig. 5

Assuming the gasoline strainer is empty, approximately 25 strokes of the primer lever are required to fill the bowl. See Fig. 5. After strainer bowl is full, an additional 5 to 10 strokes are required to fill the carburetor bowl. When carburetor is full the hand primer lever will move more easily.

IGNITION SWITCH

Magneto ignition is standard on these engines. A lever type switch, on the side of the magneto, is always in the **on** or running position, except when depressed for stopping the engine. See Fig. 1 and Fig. 2A.

On engines with a house, the ignition switch is on the outside of the house at the flywheel end. See Fig. 2. When starting or stopping engine, follow instructions on switch tag. This will apply to both **magneto** and **battery ignition.**

STARTING

STARTING PROCEDURE

1. Check crankcase and air cleaner oil level, and fuel supply. Open shut-off valve in fuel strainer.
2. Disengage clutch, if furnished.
3. New engine may require priming; refer to "Fuel Pump" paragraph for instructions.
4. Set throttle about 1/2 open if variable speed governor control is furnished; for a two-speed control, start in full load position, and with a fixed speed governor, spring will hold throttle open for starting.
5. Pull out ignition switch button, if applicable. (Switch tag reads "To Stop Push In"). Refer to *Ignition Switch* paragraph.
6. Close carburetor choke by pulling choke button to extreme out position.
7. Turn engine over one or two revolutions. Push choke button in about half-way and then pull up briskly on the starting crank. **Do not** attempt to *spin* the engine with the starting crank. If the engine does not start on the first pull up of crank, re-engage the crank and repeat the operation.

With electric starting motor; depress starter button in place of hand cranking.

8. After engine starts, push choke button in as required for smooth running. Choke must be completely open when engine is warmed up.

If flooding should occur, open choke fully, by pushing choke button in and continue cranking. More choking is necessary when starting in cold temperatures or when engine is cold, than when it is warm.

If all conditions are right, engine will start promptly after one or two attempts. Allow engine to warm up a few minutes before applying load, as prescribed in "Warm-Up Period" paragraphs.

New engines should be "run-in" gradually to insure trouble-free service. Refer to "Starting and Operation of New Engine", on the inside front cover of this manual, for correct "running-in" procedure.

WARM-UP PERIOD

The engine should be allowed to warm up to operating temperature before load is applied. This requires only a few minutes of running at moderate speed. **Racing an engine or gunning it**, to hurry the warm-up period, is **very destructive** to the polished wearing surfaces on pistons, rings, cylinders, bearings, etc., as the proper oil film on these various surfaces cannot be established until the oil has warmed up and become sufficiently fluid. This is especially important on new engines and in cool weather.

Racing an engine by disconnecting the governor, or by doing anything to interfere with the governor control engine speed, is **extremely dangerous**. The governor is provided as a means for controlling the engine speed to suit the load applied, and also as a safety

measure to guard against excessive speeds, which not only overstrain all working parts, but which might wreck the engine and possibly injure bystanders.

All parts of the engine are designed to safely withstand any speeds which might normally be required, but it must be remembered that the stresses set up in rotating parts increase with the square of the speed. That means that if the speed is doubled, the stresses will be quadrupled, and if the speeds are trebled, the stresses will be nine times as great.

Strict adherence to the above instructions cannot be too strongly urged, and greatly increased engine life will result as a reward for these easily applied recommendations.

STOPPING ENGINE

Engines, less house, have a lever type stop switch on the side of the magneto. To stop, depress lever and *hold down until engine stops*. See *Fig. 1 and Fig. 2A*.

Power units, *Fig. 2*, and battery ignition engines, are furnished with an ignition switch, "To Stop Push In".

If the engine has been running hard and is hot, do not stop it abruptly from full load, but remove the load and allow engine to run idle at 1000 to 1200 RPM for three to five minutes. This will reduce the internal temperature of the engine much faster, minimize valve warping, and of course the external temperature, including the manifold and carburetor will also reduce faster, due to air circulation from the flywheel.

MAINTENANCE

AIR CLEANERS

MODEL TJD: The oil bath type air cleaner, illustrated in *Fig. 6*, is standard equipment.

MODEL W2-880: The dry element air cleaner, illustrated in *Fig. 6A*, is standard equipment.

MODEL STJD and W2-880: A dry element (tri-phase) air cleaner, illustrated in *Fig. 7*, is optionally available.

The air cleaner is an essential accessory, filtering the air entering the carburetor and preventing abrasive dirt from entering the engine and wearing out valves and piston rings in a very short time.

The air cleaner must be serviced frequently, depending on the dust conditions in which the engine is operated. Check connections for leaks or breaks and replace all broken or damaged hose clamps on remote or side mounted air cleaners.

Excessive smoke or loss of power are good indications that the air cleaner requires attention.

OIL BATH AIR CLEANER, (Fig. 6)

Once each week; the filtering element should be thoroughly washed in a solvent. Remove oil and clean out air cleaner bowl. Add fresh oil to the *level line* indicated on bowl, using the same grade oil as is used in the engine crankcase.

Service daily, if engine is operating in very dusty conditions. Detailed instructions are printed on the air cleaner.

Operating the engine under dusty conditions without oil in the air cleaner or with dirty oil, may wear out cylinders, pistons, rings and bearings in a few days time, and result in costly repairs.

Plastic pre-cleaner, mounted to the top of the air cleaner, removes the larger dirt and dust particles before the air reaches the main air cleaner.

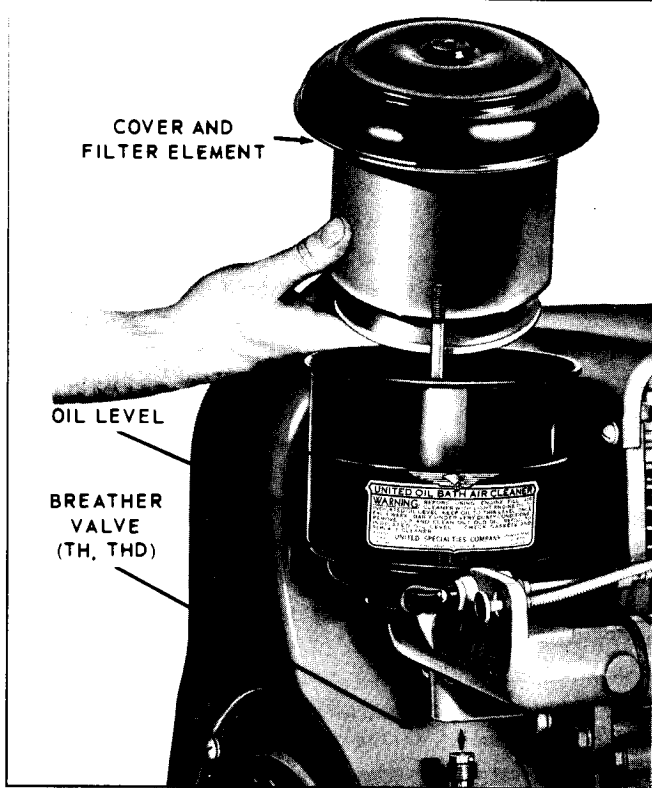

Fig.6

Clean bowl regularly of accumulated dust and dirt. **Do not use oil or water in pre-cleaner, this must be kept dry.**

DRY TYPE AIR CLEANER (Fig. 6A)

The dry element air cleaner is mounted directly to the carburetor. **Do not oil element, and do not use gasoline or kerosene for cleaning.**

Service Daily; or twice a day if engine is operating in very dusty conditions. Remove element and shake out the accumulated dust and dirt. Wipe out dirt from inside cover and from housing.

Once Each Week; The filtering cartridge should be taken out and rinsed under a faucet with cold water, then wash by repeated dippings for several minutes in a solution of lukewarm water and a mild, **non-sudsing** detergent. Rinse in cold water from the inside out, and allow to dry overnight before installing in air cleaner. In cold weather, protect element from freezing until dry.

After five washings or one year of service, which ever comes first, replace the cartridge element. New filter elements are available from all Wisconsin Distributors and Service Centers.

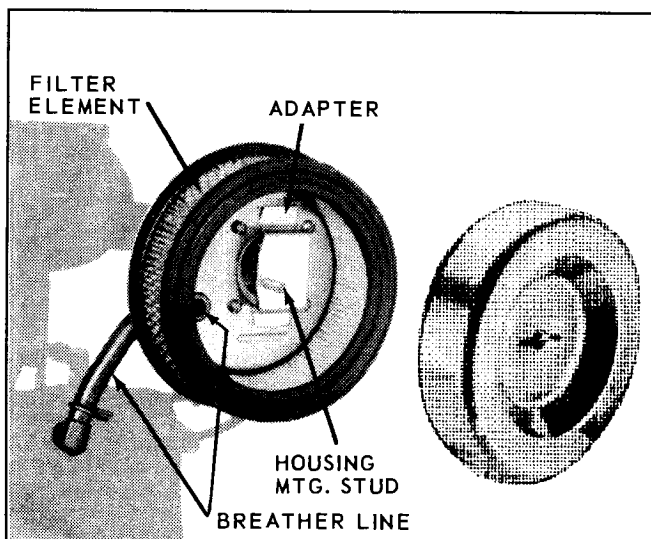

Fig. 6A

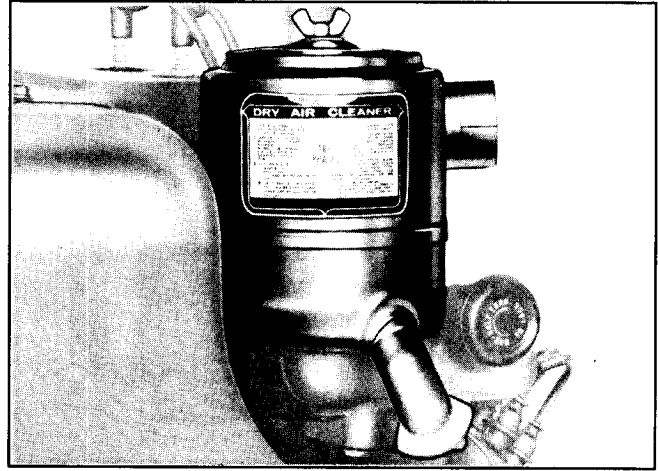

Fig. 7

DRY ELEMENT (TRI-PHASE) AIR CLEANER (Fig. 7)
Service Daily; squeeze rubber dust unloader once or twice a day to check for possible obstruction. If engine is operating in very dusty conditions, remove cartridge and shake out accumulated dirt (do not tap or strike element—it may become damaged). Wipe out dirt from inside cover and bowl.

Once Each Week; The filtering cartridge should be taken out and either dry-cleaned with compressed air, or washed by repeated dipping for several minutes in a solution of lukewarm water and a mild, **non-sudsing** detergent. Rinse in cold water from the inside out, and allow to dry overnight before installing. In cold weather, protect element from freezing until dry. **Do not oil element, and do not use gasoline or kerosene for cleaning.**

After ten washings or one year of service, which ever comes first, replace cartridge. New cartridges are available at your Wisconsin dealer. Refer to Illustrated Parts Catalog for replacement part number.

Carry a spare element in a dust-proof container for quick replacement in the field. Clean dirty element when convenient.

CRANKCASE BREATHER

Models *TH* and *THD* have a ball check **breather valve** mounted to the bottom of the air cleaner bracket and channeled thru the gear cover to the crankcase. The breather valve, removed as illustrated in Fig. 6, should be kept free of dirt by periodic cleaning.

Models *TJD* and *W2-880*: The characteristics of this engine are such that a ball check valve is not required in its breather system.

A restricted or plugged up breather system is indicated when oil seeps from gasket surfaces, oil seals, screws and studs.

FUEL FILTER (Fig. 8)

It is very important that gasoline be filtered to prevent sediment, dirt and water from entering the carburetor and causing trouble or even complete stoppage of the engine. The fuel filter has a glass bowl and should be inspected frequently, and cleaned if dirt or water are present.

To remove sediment bowl, loosen nut below bowl and swing wire bail to one side. There will be less danger of breaking the gasket if the bowl is given a twist as it is being removed. Clean bowl and screen thoroughly. Replace gasket if it has become damaged or hardened. Repair kits are available for service replacement, refer to Illustrated Parts Catalogs.



Fig.8

CARBURETOR ADJUSTMENT

The *main metering jet* in the carburetor is of the fixed type and therefore no adjustment is necessary.

The correct amount of throttle plate opening for the proper low idle speed is obtained by means of the *throttle stop screw*. However, this is set at the factory so that no immediate adjustment is necessary. The *idle adjustment* is for smooth low speed operation and this adjustment, if necessary, must be made with the carburetor throttle lever closed.

For further information, refer to Carburetor Service Instructions in this manual.

MAGNETO IGNITION

MAGNETO IGNITION SPARK (Fig. 9)

If difficulty is experienced in starting the engine or if engine misses firing, the strength of the ignition spark can be tested as follows: Remove the ignition cable from the No. 1 spark plug and wedge a piece of stiff bare wire up into the terminal boot with one end of the wire extending out. With the extended wire held about 1/8 inch away from the cylinder head shroud, turn the engine over slowly by the starting crank and watch for the spark discharge, which should occur during the cranking cycle, at the instant the impulse coupling on the magneto snaps. Repeat this check with the other ignition cable. If there is a weak spark,

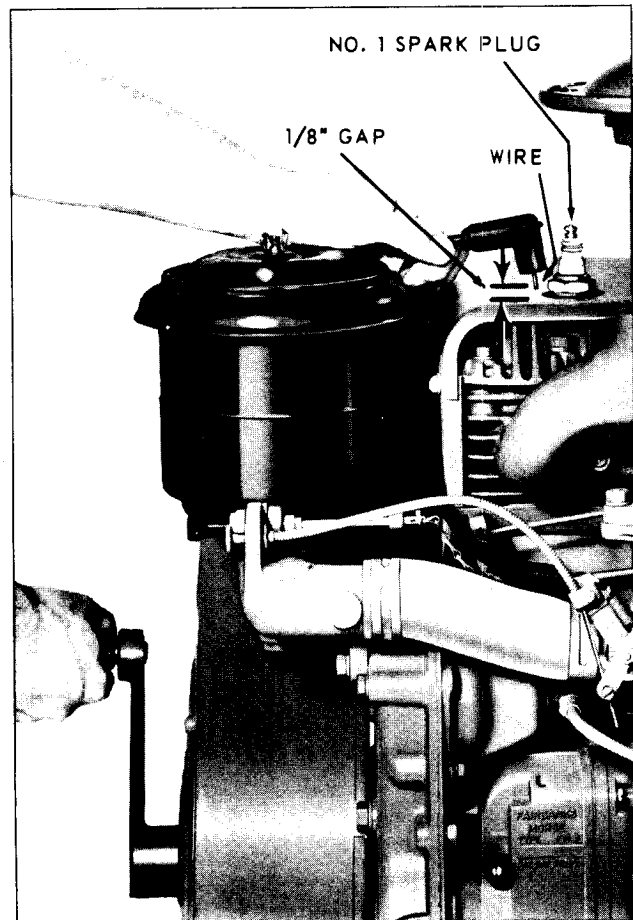

Fig. 9

or none at all, check breaker point opening as described in "Magneto Breaker Point Adjustment". If this does not remedy the trouble, it may be necessary to install a new condenser. See Magneto Service Instructions in this manual.

MAGNETO BREAKER POINT ADJUSTMENT (Fig's. 10, 11)

The magneto *breaker point gap* is .015 inch at full separation. If the ignition spark becomes weak after continued operation, the breaker points may have to be readjusted, resurfaced or replaced. Remove the magneto end cover and take off *rotor* in order to examine the points. If there is evidence of pyramiding or pitting, the points should be resurfaced with a small tungsten file.

Points that are badly worn or pitted should be replaced. Check breaker point gap by rotating the crankshaft with the starting crank, (this also rotates the magneto), until the breaker points are wide open. The opening or gap should then be measured with a feeler gauge as shown.

Adjust breaker points as follows: First loosen the two *locking screws* on the *contact plate* enough so

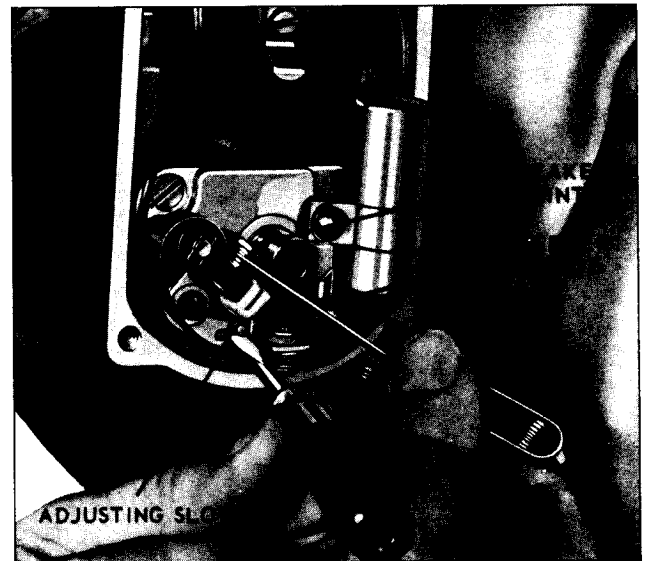
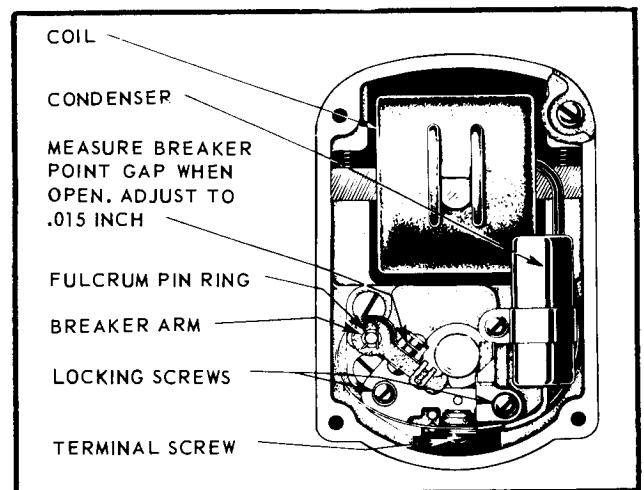

Fig. 10



END VIEW OF FAIRBANKS-MORSE MAGNETO
Fig. 11

that the plate can be moved. Insert the end of a small screw driver into the *adjusting slot* at the bottom of the *contact plate* and open or close the contacts by moving the plate until the proper opening is obtained. After tightening the locking screws, recheck breaker point gap to make sure it has not changed. Place rotor on shaft before mounting end cover. **CAUTION:** Rotor is so constructed that it can only be put on in the correct position relative to timing.

Mount magneto end cover and gasket carefully, so that they seal properly. Do not turn cover screws too tightly, otherwise cover may crack. For further information see Magneto Service Instructions in this manual.

MAGNETO TIMING (Fig. 12)

Drive gear replacement on Models TJD and W2-880 requires the gear to be positioned on the drive lugs of the magneto so that when No. 1 terminal fires, the 'X' marked gear tooth is visible through the timing hole, while flywheel is positioned as illustrated in Fig. 12. Refer to Magneto Service Instruction in this manual for further information on gear mounting.

The *magneto* is mounted and retimed to the engine in the following manner:

1. Remove screen over flywheel air intake opening to expose the *timing marks* on flywheel and shroud.
2. Remove No. 1 spark plug (that which is closest to flywheel end of engine). Then, hold thumb over spark plug hole and turn engine over slowly with the crank until a definite pressure can be felt,

tending to push the thumb away from plug opening. When this occurs, No. 1 piston is coming up on compression stroke.

3. Continue cranking until the leading edge of the *X marked vane* and *DC* letters on flywheel are in line with the *vertical centerline* mark on shroud, as shown on Timing Diagram, *Fig. 12*. Leave flywheel in this position, as the No. 1 piston is now on top dead center.
4. Remove *inspection hole plug* from magneto timing in the engine gear cover.
5. Assuming the magneto is removed from the engine; set magneto for spark discharge to the No. 1 terminal. This is accomplished by use of a short stiff length of wire placed into the No. 1 terminal socket and bent to within 1/8 inch of the magneto frame. Then turn the magneto gear in a clockwise rotation, tripping the impulse coupling, until a spark is observed between the wire and frame. Retain gear in this position. **NOTE:** This procedure is necessary only for the *TJD* and *W2-880* engines. *TH* and *THD* models have a split-coil magneto that produces two sparks simultaneously (one for each terminal) ever 360° of rotation.
6. Mount magneto to the engine, meshing the gears so that when magneto is in place, the gear tooth marked with an 'X' will be visible in the *center* of the *inspection hole* in gear cover. See *Magneto Timing Diagram, Fig. 12*. Tighten mounting screws and be sure flange gasket is in place.

The No. 1 spark plug ignition wire terminal on the

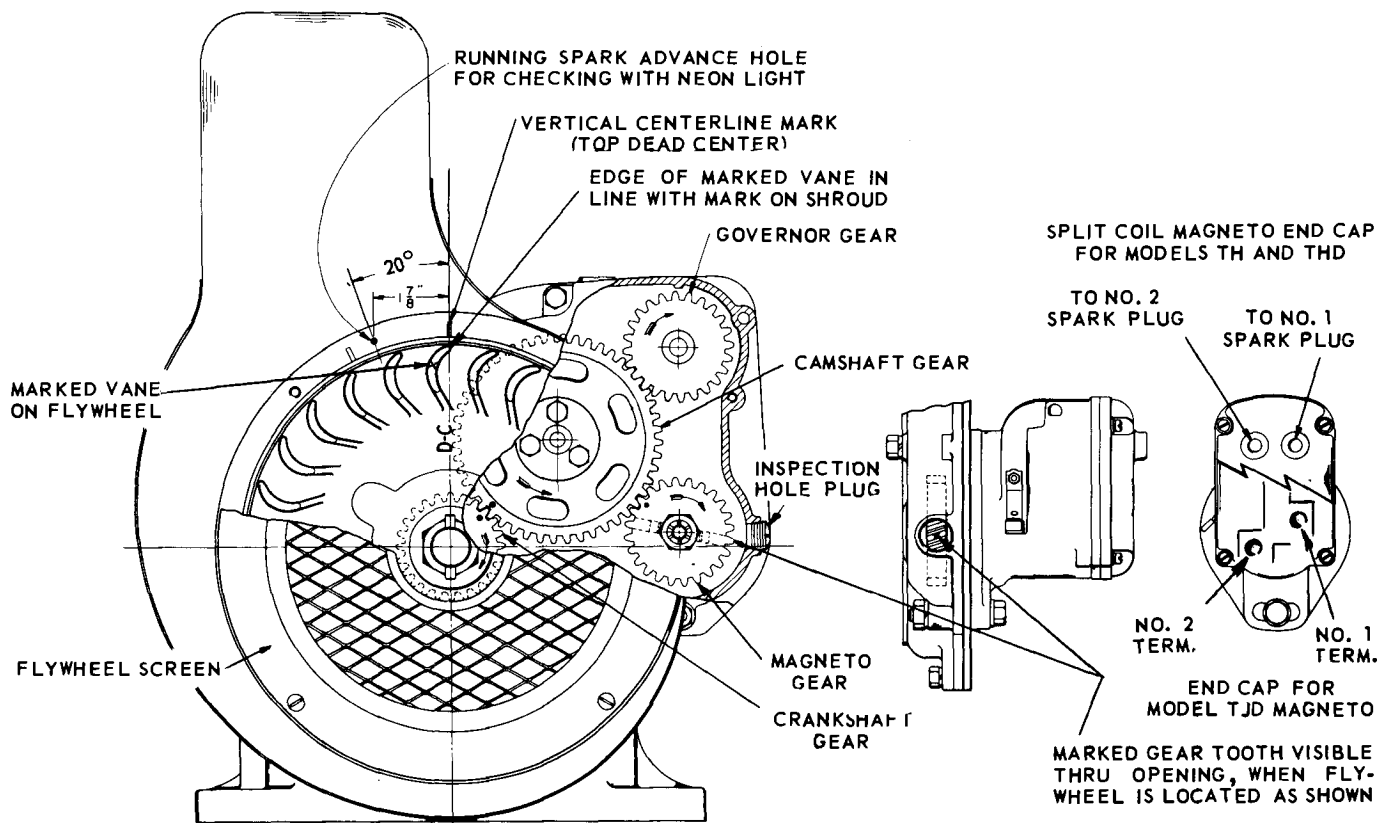

Fig. 12, MAGNETO TIMING DIAGRAM

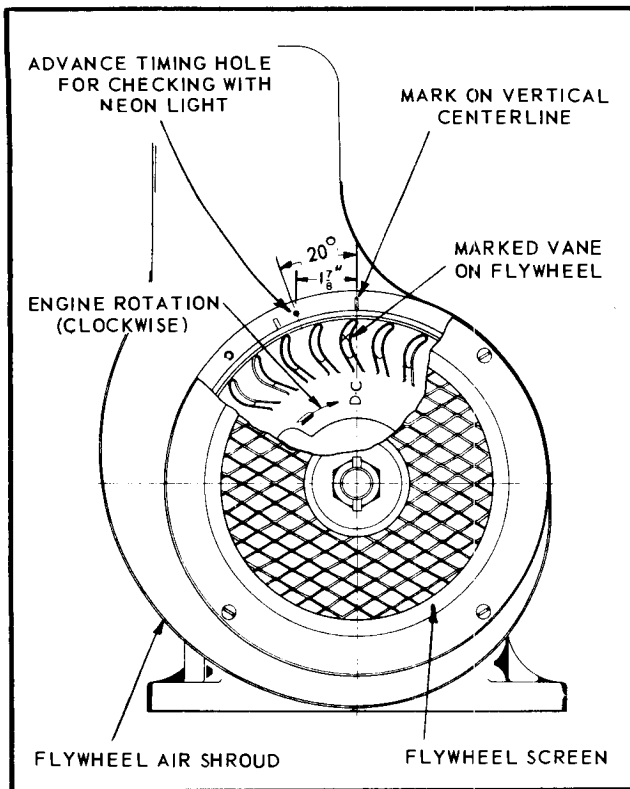

Fig. 14

magneto end cap is the tower toward the engine. See Fig. 12.

The magneto rotates at crankshaft speed in clockwise direction when viewing driving gear end. The rotor distributes one spark per revolution for each cylinder, but only the spark on compression stroke is useful. The other spark is wasted during the exhaust stroke.

The *running spark advance* is 20°. To check timing with a *neon light*, the spark advance is indicated by a 1/8" diameter hole on the flywheel shroud, 20° or 1-7/8" to the left of the vertical centerline, Fig. 14.

FIRING ORDER

In Models *TJD* and *W2-880* the firing interval between No. 1 cylinder and No. 2 is 540°, — from No. 2 to No. 1, 180°.

Models *TH* and *THD* are even firing engines, with the cylinders firing every 360° or one crankshaft revolution apart.

CAUTION: Do not use magneto or distributor for Models *TJD* and *W2-880* on Models *TH*, *THD*, or vice versa.

BATTERY IGNITION

DISTRIBUTOR

A distributor is furnished in place of magneto, on engines that are equipped with a generator or flywheel alternator.

When a *direct mounted generator* is provided, the distributor is mounted to the end of the generator frame as illustrated in Fig. 16. On engines with *belt driven generator* or *flywheel alternator*, the distributor is

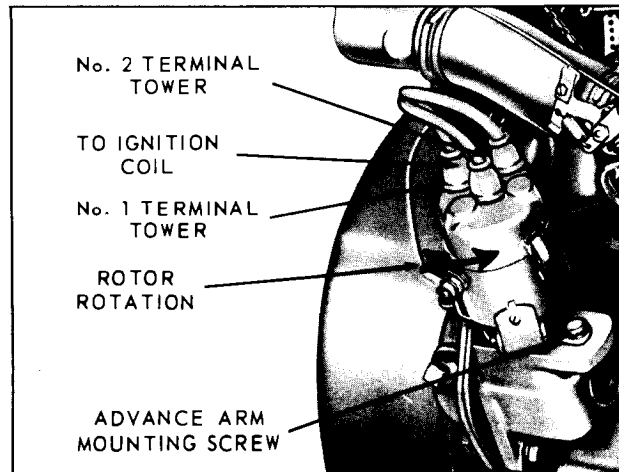

Fig. 15, DISTRIBUTOR MOUNTED TO ADAPTER HOUSING

mounted to an adapter housing attached to the gear cover where the magneto would ordinarily be mounted. See Fig. 15.

The distributor is of the automatic advance type and it is driven off an engine speed shaft through a pair of two to one ratio helical gears, thus giving the distributor one half engine speed in a counter-clockwise direction when viewed from above.

The proper *spark advance* for **NORMAL SPEEDS** (2000 RPM) is 20° BTDC, the same as for magneto ignition. **Do not time engine below 2000 RPM.**

DISTRIBUTOR TIMING

Remove screen over the flywheel air intake opening. This will expose the timing marks on flywheel shroud, also the *vane* on flywheel, marked by an 'X' and the letters 'DC', See Fig. 14. Next, remove the spark plug from No. 1 cylinder and turn engine over slowly, by means of the starting crank, and at the same time hold a finger over the spark plug hole to determine the compression stroke.

Upon reaching the compression stroke, continue turning the starting crank until the leading edge of the 'X' marked vane on flywheel is in line with the *vertical centerline mark* on the flywheel shroud, as shown

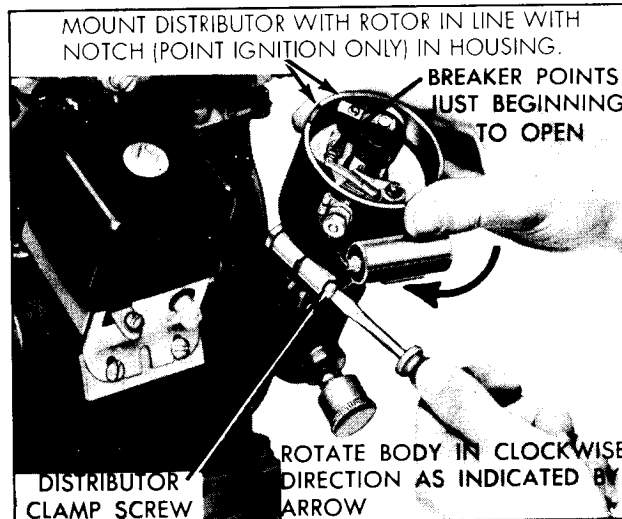

Fig. 16, DISTRIBUTOR TIMING

in Fig. 14. The No. 1 piston is now on top dead center. Reassemble spark plug.

With the No. 1 piston now on **TDC** and on compression stroke, remove cap from distributor and mount as follows:

1. Align rotor with center of notch (point ignition only) in distributor housing (location of No.1 terminal tower). Mount unit in place so that the notch is in an approximate 10 o'clock position. See Fig. 16. This applies to either distributor mounting - to the end of generator frame or adapter housing on gear cover.
2. Tighten advance arm mounting screw securely in place.
3. Adjust breaker point gap to .020 inch opening, see "Distributor Maintenance".
4. With the distributor clamp screw loose, see Fig. 16, turn the distributor body slightly in a counter-clockwise direction until the breaker points are firmly closed. Then turn the distributor body in a clockwise direction until the breaker points are just beginning to open. At this point a slight resistance can be felt as the breaker point cam strikes the breaker point arm.
5. Tighten advance arm clamp screw. No. 1 cylinder is now ready to fire in the retarded position.

The breaker point gap of .020 of an inch should be checked and adjusted per paragraph (3), before distributor body is set and locked in place, as per paragraphs (4) and (5), because any change in gap opening will affect the ignition advance. Mount distributor cap and connect ignition cables per *Wiring Diagram*, Fig. 18 or 20.

If care is exercised in the preceding instructions, the spark timing should be accurate enough for satisfactory starting, however, *checking spark advance with a neon lamp*, as described in 'Neon Lamp Timing' is necessary.

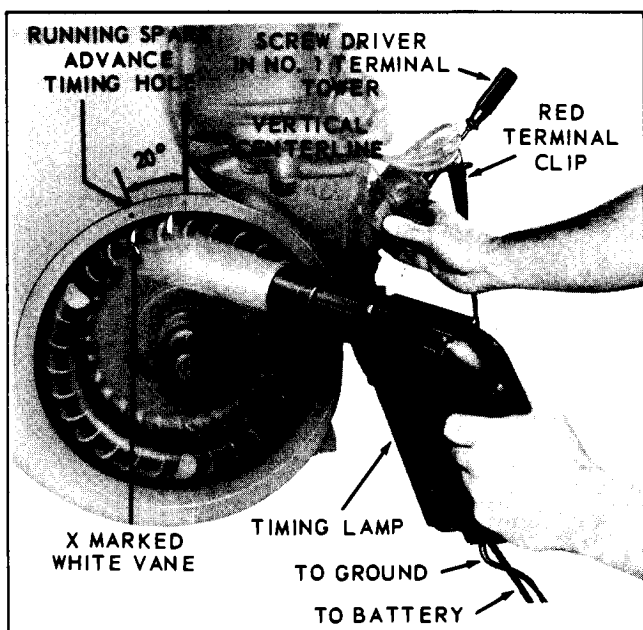

Fig. 17

NEON LAMP TIMING (Fig. 17)

The engine should be timed to the **20° advanced position at not less than 2000 R.P.M.** Check timing with a neon lamp as shown. Insert a small screw driver into the No. 1 terminal tower on the distributor cap, making contact with the spark plug wire terminal. Connect the red terminal clip, from a conventional type timing lamp, to the metal portion of the screw driver. One of the other two timing lamp wires is connected to the battery, and the other to ground.

Chalk or paint the end of the 'X' marked vane on the flywheel, white. Then, with the engine operating at **2000 R.P.M.** or over, allow the flash from the neon lamp to illuminate the whitened vane. At the time of the flash, the leading edge of the vane should line up with the *running spark advance timing hole* on the flywheel shroud. If it does not, the distributor *clamp screw* should be loosened and the distributor body turned slightly clockwise or counterclockwise, as required, until the *white flywheel vane* matches up with the *advance timing hole*. Be sure *clamp screw* is then carefully tightened.

If the engine is running below **2000 R.P.M.** when timing, the automatic advance in the distributor will not be in the "full advance position" and thus the timing would not be accurate.

DISTRIBUTOR AND GENERATOR MAINTENANCE

The breaker point gap should be .020 inch at full separation. To readjust point gap; turn engine over by means of the starting crank until the distributor breaker arm *rubbing block* is on a high point of the *cam*. Loosen the *stationary contact lock-nut*, and screw *fixed contact* in or out, until correct gap is obtained. Tighten locknut and recheck gap.

Every 50 hours of operation; the oiler in the generator commutator end head should have 3 to 5 drops of medium engine oil added.

The oiler on the side of the distributor base should have 3 to 5 drops of medium engine oil added, and the grease cup given one complete turn. Use a high melting point grease.

Every 100 hours, apply 3 to 5 drops of light engine oil (10W), to the felt in the top of the cam sleeve, and 1 or 2 drops to the breaker arm pivot.

Every 200 hours, add a small amount of high melting point grease to the breaker arm rubbing block.

Avoid excessive lubrication. Oil that may get on the contact points will cause them to burn.

ELECTRICAL WIRING CIRCUITS

NOTE: Beginning with engine serial No. 3988441, the standard wiring circuits of all **12 volt** electrical equipment for Models *TH*, *THD* is **negative ground polarity**, instead of the previously furnished positive ground. All Model *TJD* and *W2-880* electrical equipped engines are **negative ground**. Any **6 volt** systems that might be furnished remain **positive ground**.

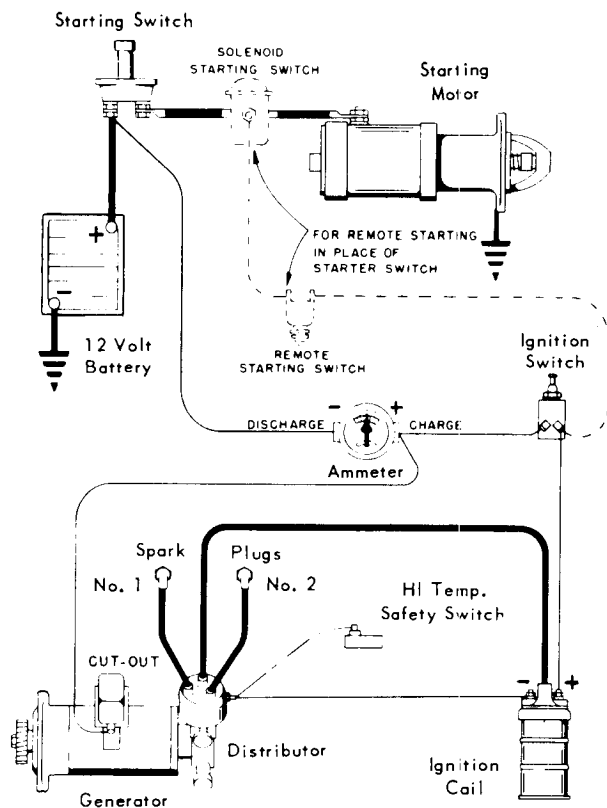

Fig. 18, WIRING DIAGRAM Battery Ignition with Generator

The wiring diagram, Fig. 18, illustrates a **negative ground** circuit. If polarity of generator is for a positive ground circuit, terminal connections at ammeter, ignition coil, and battery are reversed from those shown. **Do not** use positive ground generator and regulator in a negative ground circuit, or vice versa. Polarity does not affect starting motor, coil and distributor.

SOLID STATE IGNITION DISTRIBUTORS (TJD, W2-880 -YF52S1)

Many new Wisconsin engines are now being equipped with a solid state ignition distributor. Externally the new solid state ignition distributors are similar in appearance to a conventional point ignition distributor. Internally the major differences are:

1. Distributor cam which opens ignition points has been replaced with a magnet assembly.
2. Ignition points have been replaced with a "Hall effect type" electronic module.

This solid state ignition distributor uses two primary wire leads which attach to the ignition coil. **The black or blue lead connects the negative(-) terminal of the ignition coil while the red lead connects to the positive (+) side of the ignition coil.**

Note: the same Wisconsin coil is used on the solid state and point ignition systems.

TROUBLESHOOTING

The following steps should be performed if the engines ignition system appears to be not operating properly:

1. Visually inspect plug wires, coil wire, distributor cap and rotor. Replace any components that show deterioration. It is especially important that the cap and plug wires be in good condition, free of oil, grease and moisture.
2. Check for loose or poor connections in ignition circuit. Check battery terminals for corrosion and loose connections.
3. Check battery voltage with engine off. It should be 12 to 15 volts.

If the above items have been checked and found to be proper and the engine's distributor is believed to be faulty, the distributor should be tested.

NOTE: Ignition timing adjustment specifications and procedures for the solid state ignition systems are the same as the corresponding point ignition distributor. An automotive type timing light should be used to check and adjust ignition timing.

TESTING

Testing can be done either with a voltmeter or a 12 volt test light.

VOLT METER TESTING

1. Connect the positive (+) lead of a voltmeter to the negative (-) side of the ignition coil. Ground the negative (-) lead of the voltmeter. Set the voltmeter to DC volts on at least a 15 volt scale.
2. Disconnect the high voltage wire from the center of the distributor cap and ground it to the engine block or chassis.
3. Crank engine.
4. The voltmeter should fluctuate from a range of 1 to 2 volts to a range of 10 to 12 volts as the engine is cranked. **NOTE:** On some voltmeters the needle will appear to bounce between 1 and 12 volts.
5. If the voltmeter does not fluctuate, one of the following problems exist:
 - a. If the voltmeter shows a constant 0 reading, there is an open circuit somewhere in the primary ignition circuit.
 - b. If the voltmeter shows a constant voltage in the 1.0 to 3.5 volt range, the electronic module is shorted out.
 - c. If the voltmeter shows a constant voltage equal to the battery voltage, the electronic module has an open circuit and requires replacement.

12 VOLT TEST LIGHT

1. Connect the test light between the positive (+) side of the ignition coil and ground. With the ignition switch in the "on" position the light should light. **NOTE:** If there is no voltage present at the positive side of the coil, recheck the circuit from the battery through the ignition switch to the coil.
2. Disconnect the black primary lead going between the ignition coil negative (-) terminal and the distributor. Connect the test light to the negative (-) terminal of the ignition coil. Turn the ignition switch on - the test light should light, if not the ignition coil primary winding is open and the coil should be replaced. Reconnect the black primary lead of the distributor to the negative (-) terminal of the ignition coil. Connect the test

- light again to the negative terminal of the ignition coil.
3. Disconnect the high voltage wire from the center of the distributor cap and ground to the engine.
 4. Crank the engine.
 5. The test light should flicker as the engine is cranked.
 6. If the light does not flicker then the distributor electronic module is faulty.

NOTE: To avoid damage to the distributor components the following conditions must be avoided:

1. **REVERSE POLARITY** - **Do not** reverse the battery cables - (this distributor is for negative ground systems only) or the ignition coil wires. **Black coil lead to negative terminal of the coil; red lead to positive terminal of the coil.**
- NOTE:** Some early production distributors have a blue lead instead of a black lead for the negative coil lead.
2. **VOLTAGE SURGES** - **Do not** operate the engine with the battery disconnected. Insure all electrical connections are made properly. Avoid using switches on the engine which cause excessive arcing.
3. Disconnect the ground (negative) cable when charging the battery.
4. **JUMP STARTING** - Only use another 12 volt battery for jump starting - be sure battery polarity is correct (positive to positive, negative to negative.)

NOTE: A HIGH AMPERAGE BOOST CHARGER CAN DAMAGE THE SOLID STATE COMPONENTS WITHIN THE DISTRIBUTOR.

FLYWHEEL ALTERNATOR (Fig. 19)

12 volt - 10 amp or 25 amp flywheel alternator is used in place of the flange mounted gear driven generator. These units are of the permanent magnet type and have **no brushes, commutator, belts or adjustments.**

Beginning with engine serial No. 5190298, a new **two module** flywheel alternator system replaces the previously furnished three module system, that included an isolation diode module, and the two unit system without the isolation diode. Refer to **Bulletin MY-89-8** for **Obsolete Flywheel Alternator** information.

Since the physical appearance of both 10 amp and 25 amp alternator systems are very similar, the **25 amp unit** can be distinguished from the **10 amp unit** by the ammeter calibrations, and by a **14 gage green wire** in place of a **16 gage red wire**, from the ammeter to the stator-regulator connector.

NOTE: Refer to pages 30-32 for detailed testing and troubleshooting information.

SPARK PLUGS (Fig. 21)

Incorrect gap, fouled or worn spark plug electrodes, will have an adverse affect on engine operation. Remove spark plugs periodically, clean, regap or replace if necessary. Thread size is 18 mm.

Spark plug gap - 0.030 of an inch.

Replacement plugs must be of the correct heat range, like Champion No. D-16J, AC No. C86 commercial.

Use a new gasket when mounting either old or new plug and thoroughly clean threads in cylinder head before installation. Tighten spark plug **24 to 26 foot pounds torque**. If torque wrench is not available, tighten plug until it begins to seat on the gasket, then turn 1/2 to 3/4 of a turn more.

HIGH TEMPERATURE SAFETY SWITCH (Fig. 22)

As a safety precaution against overheating, engines can be equipped with a high temperature switch, mounted to a cylinder head bolt opposite the **No. 2** spark plug.

When cylinder head temperature becomes critically high, the safety switch will automatically stop the engine by shorting out the ignition system. A waiting period of about **10 minutes** will be required before the switch has cooled off sufficiently to re-start the engine. An overheated engine will score the cylinder walls, burn out connecting rod and crankshaft bearings, also warp piston and valves. The cause of the overheating condition will have to be remedied before the engine is re-started. See **Overheating** paragraph in **Troubles, Causes, and Remedies** section.

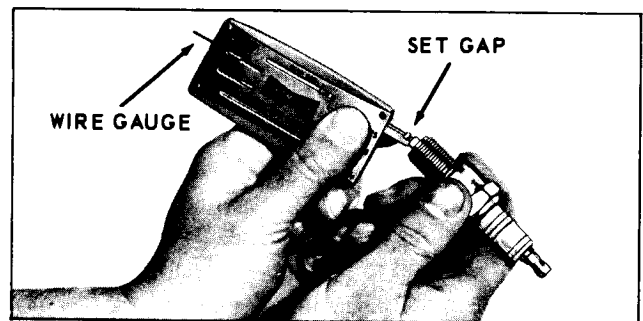

Fig. 21

A **High Temperature Safety Switch service kit** is available for installation on engines in the field. Refer to **"DISTRIBUTORS"** in the **OPTIONS AND ACCESSORIES** Section of the **Wisconsin Counter Manual for Illustrated Parts List and Mounting Locations.**

RESTORING COMPRESSION

On a new engine or on one which has been out of operation for some time, the oil may have drained off the cylinder so that

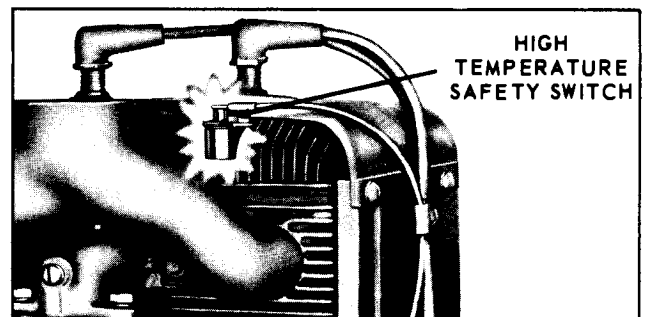

Fig. 22

compression will be weak, This may cause difficulty in starting. To remedy this condition, remove the spark plugs and pour about a fluid ounce of crankcase oil through the spark plug hole into each cylinder.

Turn the engine over several times with the starting crank to distribute the oil over the cylinder wall. Then reassemble spark plugs and compression should be satisfactory.

GOVERNOR

OPERATION

The centrifugal flyball governor rotates on a stationary pin driven into the upper part of the timing gear cover, and the *governor is driven* off the camshaft gear *at crankshaft speed*.

Flyweights are hinged to lugs on the drive gear. Hardened pins on the flyweights bear against the flanged sliding sleeve, moving it back and forth as the flyweights move in or out. The motion of the sleeve is transmitted through a ball thrust bearing to the governor lever, which in turn is connected to the carburetor throttle lever. A spring connected to the governor lever tends to hold the flyweights to their *inner* position, also to hold the carburetor throttle open. As the engine speed increases, centrifugal force from the flyweights acts against the spring and closes the throttle to a point where the engine speed will be maintained practically constant under varying load conditions.

GOVERNOR ADJUSTMENT (Fig. 23, Fig. 23A, Fig. 24, & Fig. 24A)

The governor rod connection to the carburetor must be very carefully adjusted for length, otherwise the governor will not function properly and cause the engine to surge badly. With the engine at rest, the governor spring will keep the flyweights *in*, and the control rod must be of such length as to hold the carburetor throttle wide open at that point.

CONTROL ROD

W2-880, TJD, THD, TH - With the *control rod* disconnected from the *governor lever*, push the rod toward the carburetor as far as it will go. This will put the *carburetor throttle lever* in a wide open position.

The governor lever should then be moved as far as possible in the same direction. Holding both parts in the above position, the rod should be screwed in or out of the *swivel block* on the carburetor, until the bent end of the rod will register with *hole* in lever, then screw rod in one more turn. The extra turn will shorten the linkage slightly and will enable the carburetor throttle lever to bounce back from the stop pin rather than jam against the pin, when a load is suddenly applied to an idling engine. This will eliminate excessive wear on the threads in the carburetor throttle swivel block.

W2-880 - Remove retaining clip and disconnect the control rod from the carburetor throttle lever (Fig. 23A). Move the top of the governor lever toward the take off end of the engine. Hold the carburetor throttle lever in the wide open position against the carburetor stop. Adjust length of control rod so rod will register in hole in carburetor throttle lever, then lengthen rod one full turn so carburetor throttle lever will stop just short of wide open

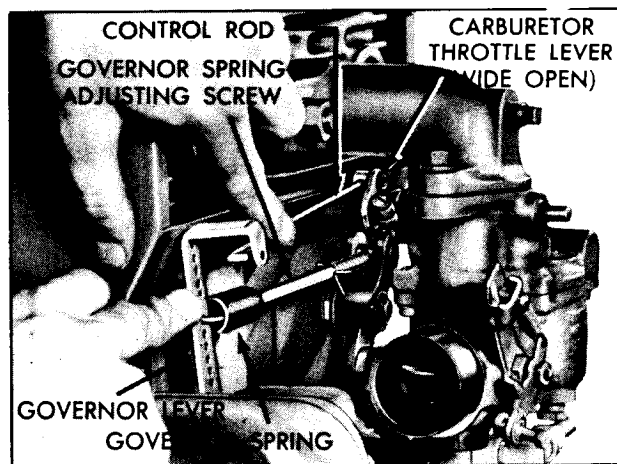

Fig. 23

LOAD R.P.M.	NO LOAD R.P.M.	HOLE NO.	
1600	1725	3	Use PM-75 Spring (20 coils)
1700	1800	3	
1800	1925	4	
1900	2000	4	
2000	2140	5	
2100	2210	5	
2200	2365	6	
2300	2420	6	
2400	2540	7	Use PM-76 Spring (24 coils)
2500	2675	8	
2600	2775	6	
2700	2870	6	
2800	2935	6	
2900	3090	7	
3000	3160	7	
3100	3230	7	
3200	3390	8	
3300	3430	8	
3400	3590	9	
3500	3640	9	
3600	3775	10	

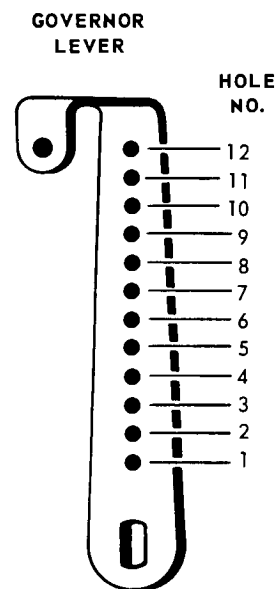

Fig. 24, GOVERNOR LEVER CHART (TJD, THD, TH)

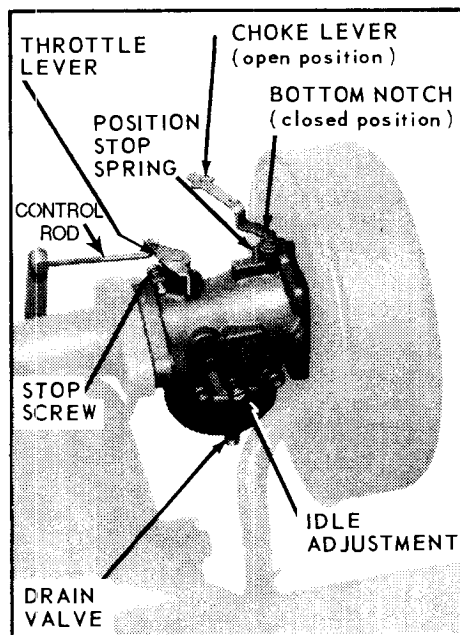

Fig. 23A

throttle stop when governor lever is in the wide open position. Reinstall retaining clip.

GOVERNOR SPRING

The model TJD, THD, TH governor lever, Fig. 24, is furnished with 12 holes for attaching the governor spring and it is very important that the spring be hooked into the hole relative to the speed at which the engine is to be operated. As noted in Governor Lever Chart, Fig. 24, two different *springs* are used on models TJD, THD, TH for the full range of operating speeds.

The model W2-880 governor lever, Fig. 24A, is furnished with 12 holes for attaching the governor spring. It is very important that the spring be hooked into the hole relative to the speed at which the engine is to be operated. As noted in Governor Lever Chart, Fig. 24A, one spring is used on model W2-880 for the full range of operating speeds.

The charts, which show the **full load** and **no load** speeds of the engine and the **hole** corresponding thereto, is for a **variable speed governor**. (Fixed speed governor settings can be obtained from a Wisconsin distributor by engine specification number). Note that the **full load** speed is less than the **no load** speed and this must be taken into consideration when readjusting the governor. As an example, in the governor lever chart, Fig. 24; if the engine is to be operated at 2400 revolutions per minute under load, the spring should be hooked into the **7th** hole in the governor lever, and the spring tension adjusted by means of the adjusting screw, to run 2540 RPM at no load. When load is applied, the engine will run at approximately 2400 RPM.

CAUTION: The model TH engine is not operated above load speed of 2600 RPM.

A tachometer or revolution counter should be used against the crankshaft to check speed while adjusting the governor spring tension. Tightening the adjusting screw locknut will give higher speeds, while loosening the locknut will lower the spring tension and reduce the RPM.

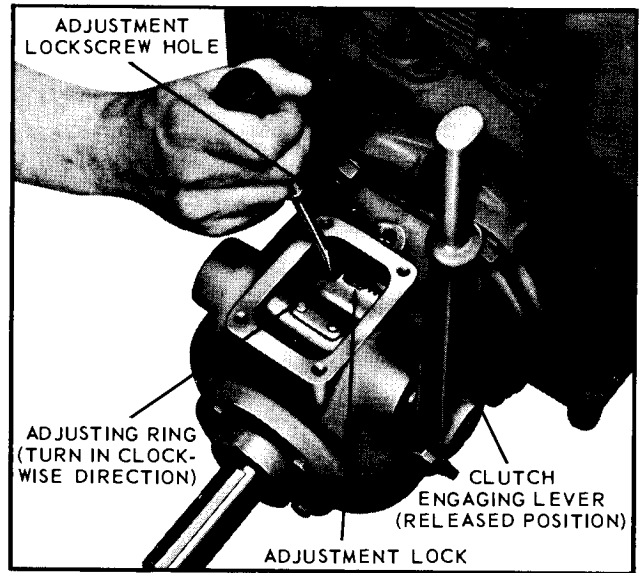

Fig. 26

LOAD R.P.M.	NO LOAD R.P.M.	HOLE NO.	GOVERNOR LEVER HOLE NO.
1600	1700	2	
1700	1800	2	
1800	1890	2	
1900	2000	3	
2000	2075	3	
2100	2160	3	
2200	2270	4	
2300	2370	4	
2400	2470	5	
2500	2580	5	
2600	2720	6	
2700	2780	6	
2800	2860	6	
2900	2990	7	
3000	3095	8	
3100	3195	9	
3200	3300	9	
3300	3375	9	
3400	3500	10	
3500	3600	11	
3600	3695	11	

Fig. 24A, GOVERNOR LEVER CHART (W2-880)

CLUTCH AND REDUCTION UNITS

CLUTCH POWER TAKE-OFF (Fig. 25)

The clutch available on these models of engines is of the disc type running in oil. Use the same grade of oil in the clutch as is used in the crankcase of the engine. Fill through the inspection plate opening, to the height of the oil level plug with approximately 1 pint of oil.

CLUTCH ADJUSTMENT (Fig. 26)

If the clutch begins to slip, it should be readjusted to prevent it from becoming overheated and damaged. First remove the inspection plate which will expose the notched adjusting ring. Release the clutch, by pushing the engaging lever forward (toward engine). Turn engine over until the clutch adjustment lock is visible thru the inspection opening. Loosen adjustment lock screw, one full turn. The lock screw is accessible thru the pipe plug hole behind the inspection opening. Keep the crankshaft from turning, then by means of a screwdriver as shown, turn the adjusting ring, one notch at a time in a clockwise direction, until a very firm pressure is felt when engaging the clutch with the lever, as the clutch snaps into engaged position. Securely tighten adjustment lock screw. Assemble inspection plate, being sure that the gasket fits properly and is not broken.

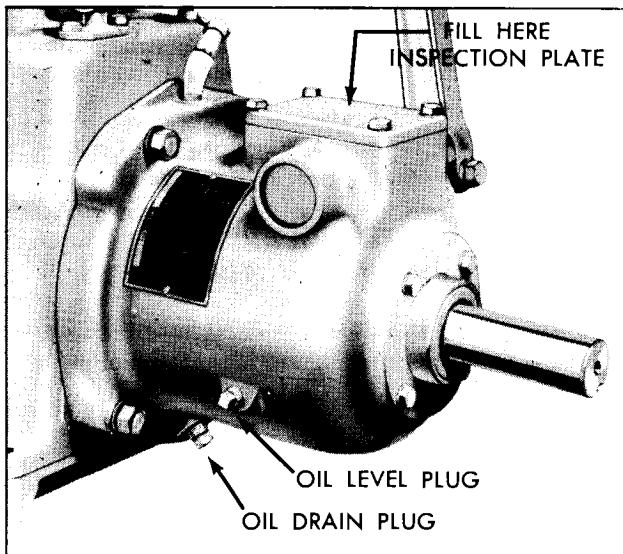

Fig. 25

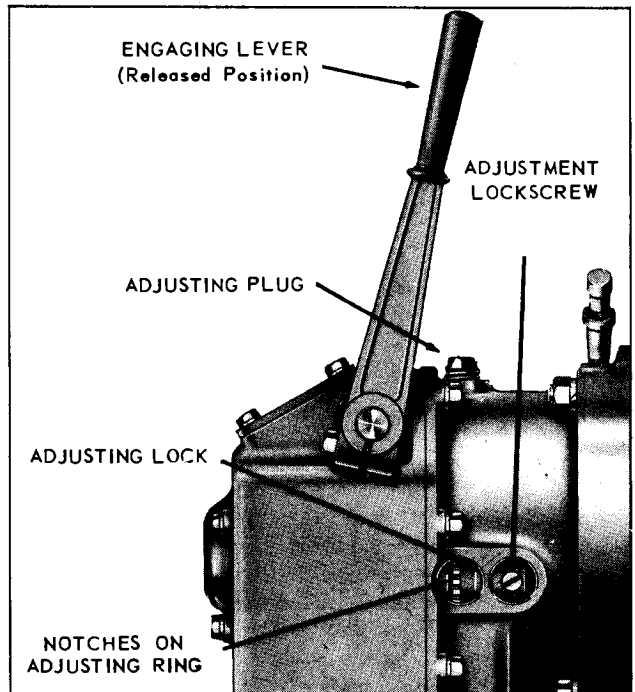

Fig. 27

CLUTCH REDUCTION UNIT

ADJUSTMENT (Fig. 27)

The clutch in the clutch reduction unit is the same as used in the clutch take-off assembly. Clutch adjustment is made thru two pipe tap openings; one for the **adjustment lock screw** and the other for turning the **adjusting ring**. If one of the taps is inaccessible, adjustment can be made thru just one opening, by rotating clutch slightly after adjustment lock screw is loosened.

Remove the two adjusting plugs; one on the left hand side of the housing, and the other on the opposite side near the top. Disengage the clutch and turn engine over slowly with the starting crank until the **adjustment lock screw** is visible thru one of the pipe tap openings. Loosen **lock screw** one full turn, or enough to relieve the tension of the lock against the notches on the **adjusting ring**. Then, thru the other pipe tap opening, turn the **adjusting ring** with a screw driver, one notch at a time in a clockwise direction (viewing from take-off end), until a very firm pressure is required to engage the clutch with the lever. Tighten adjustment lock screw and mount pipe plugs, when adjustment is completed.

REDUCTION GEARS (Fig. 28)

Reduction gears are furnished with several different ratios, some with spur gears, others with chain drives. All are of the same general design, except that some are furnished with clutches, others without.

Use same grade oil as used in engine crankcase.

Several plugs are furnished so that lubrication may be properly taken care of regardless of the position of installation. There will always be one plug on top to be used for filling oil, one plug below for draining oil, and a plug on the side, slightly above bottom, for the oil level. The oil should always be filled when the engine is at rest. When oil becomes dirty it should be drained while the engine is hot, and fresh oil added. The frequency at which these oil changes should be made depends entirely on the kind of service in which these gears are used, but even with light service;

Change oil at least every 500 hours of operation.

Add sufficient oil between changes to keep oil up to the level plug opening.

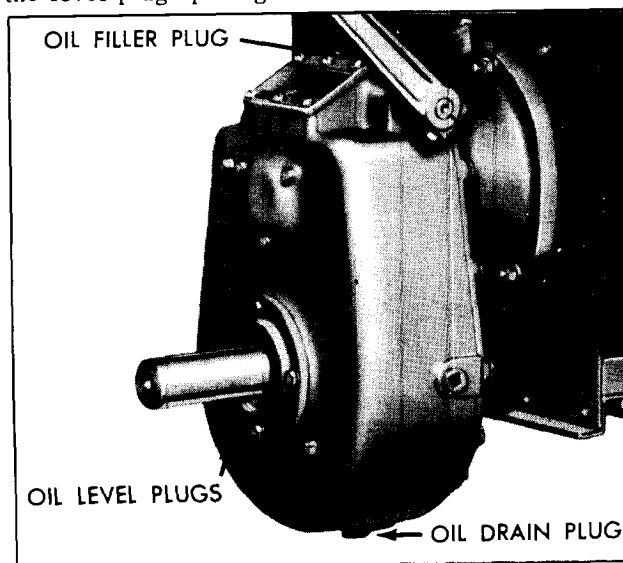

Fig. 28

WINTER STORAGE

To protect the cylinders, pistons, rings and valves and keep them from rusting and sticking, a half and half mixture of kerosene and good "gasoline engine" oil (the same kind of oil as used in the crankcase of the engine), should be injected into the **pipe tap** opening on the **intake manifold** while the engine is warm and running at moderate speed. About a quarter of a pint is necessary, or enough so that a heavy bluish smoke will appear at the exhaust. The ignition switch should then be shut off and the engine stopped. This fogging operation will leave a coating of oil on the above mentioned parts, protecting them from the atmosphere.

Drain crankcase oil while engine is warm.

Drain fuel lines, carburetor, fuel pump and tank, to prevent lead and gum sediment from interfering with future operation. Gasoline fumes from gradual evaporation is a dangerous **fire hazard**.

The air cleaner and filter element should be thoroughly cleaned. Tape or otherwise seal off the exhaust and air cleaner openings for the duration of storage.

The outside of the engine, including the cooling fins on the cylinder and head, should be thoroughly cleaned of all dirt and other deposits. All exposed unpainted metal parts should be coated with grease or heavy oil.

Before starting the engine, after the storage period, remove crankcase drain plug so that any condensation which may have collected may be drained, before new crankcase oil is added. It is highly recommended to remove the crankcase oil base and scrub off all sediment which may have collected there. When replacing the engine base, a new gasket should be used.

Fill crankcase with the correct grade of oil to the full mark on the saber. Do not use any oil heavier than SAE No. 30. Add oil to air cleaner if oil bath type is used. (Refer to Lubrication and Air Cleaner.)

It is advisable to use new spark plugs at the beginning of the operating interval, especially if the engine has given considerable service.

Refuel engine and follow the starting instructions as shown on preceding pages of this manual.

It is suggested that equipment be stored inside a building. If this is not possible, protect the engine from the weather by a proper covering.

TROUBLES CAUSES AND REMEDIES

Three prime requisites are essential to starting and maintaining satisfactory operation of gasoline engines. They are:

1. **A proper fuel mixture** in the cylinder.
2. **Good compression** in the cylinder.
3. **Good spark, properly timed**, to ignite the mixture.

If all three of these conditions do not exist, the en-

gine cannot be started. There are other factors which contribute to hard starting; such as too heavy a load for the engine to turn over at low starting speed, a long exhaust pipe with high back pressure, etc. These conditions may affect starting, but do not necessarily mean the engine is improperly adjusted.

As a guide to locating any difficulties which might arise, the following causes are listed under the three headings: *Fuel Mixture*, *Compression*, and *Ignition*. In each case, the causes of trouble are given in the order in which they are most apt to occur. In many cases the remedy is apparent and therefore no remedies are suggested.

STARTING DIFFICULTIES

FUEL MIXTURE

No fuel in tank or fuel shut-off valve closed.

Fuel pump diaphragm worn out or punctured.

Carburetor not choked sufficiently, especially if engine is cold. *See 'Starting Procedure'.*

Water, dirt, or gum in gasoline interfering with free flow of fuel to carburetor.

Poor grade or stale gasoline that will not vaporize sufficiently to form the proper fuel mixture.

Carburetor flooded, due to excessive choking. *See 'Starting Procedure'.*

Dirt or gum holding float needle valve in carburetor open. This condition is indicated if fuel continues to drip from carburetor with engine standing idle. Often tapping the float chamber of the carburetor very lightly with the wood handle of a tool will remedy this trouble. Do not strike carburetor with any metal tool.

If due to flooding, too much fuel should have entered the cylinder in attempting to start the engine, the mixture will most likely be too rich to burn. In that case, the spark plugs should be removed from the cylinders and the engine then turned over several times with the starting crank, so the rich mixture will be blown out through the spark plug holes. The choke should of course be left open during this procedure. The plugs should then be dried off, assembled, and starting tried again.

To test for clogged fuel line, loosen fuel line nut at carburetor slightly. If line is open, fuel should drip out at loosened nut.

COMPRESSION

Compression check with a commercial compression test gauge can show whether or not an engine has faulty compression. TTP does not consider it practical to publish a PSI compression figure because of the variables involved: engine condition, method of testing, and RPM of test. Our recommendation is that whatever gauge test is performed, a 10% variance between cylinders would indicate leaking rings, leaking valves or any of the following:

Cylinder dry due to engine having been out of use for some time. *See 'Restoring Compression'.*

Loose or broken spark plug. In this case, a hissing noise will be heard in cranking engine, due to escaping gas mixture on compression stroke.

Damaged cylinder head gasket or loose cylinder head. This will likewise cause hissing noise on compression stroke.

Valve stuck open due to carbon or gum on valve stem.

Valves adjusted with insufficient clearance under valve stems. *See 'Valve Tappet Adjustment'.*

Piston rings stuck due to carbon accumulation. If rings are stuck very tight, remove piston and connecting rod assembly and clean parts.

Scored cylinders. This will require reboring and fitting with oversize pistons and rings, or replacement of complete cylinder block.

IGNITION

See 'Magneto Ignition Spark', or 'Distributor-Battery Ignition'. No spark may also be attributed to the following:

Ignition cable disconnected from magneto, spark plugs, distributor or coil.

Broken ignition cables, causing short circuits.

Ignition cables wet or oil soaked.

Spark plug insulators broken. Plugs wet or dirty.

Spark plug point gap wrong. *See 'Spark Plugs'.*

Condensation on spark plug electrodes.

Magneto or Distributor breaker points pitted or fused.

Magneto or Distributor breaker arm sticking.

Magneto or Distributor condenser leaking or grounded.

Spark timing wrong. *See 'Magneto Timing' or 'Distributor-Battery Ignition'.*

ENGINE MISSES

Spark plug gap incorrect. *See 'Spark Plugs'.*

Worn and leaking ignition cables.

Weak spark. *See 'Magneto Ignition Spark' or 'Distributor-Battery Ignition'.*

Loose connections at ignition cable.

Magneto or Distributor breaker points pitted or worn.

Water in gasoline.

Poor compression. *See 'Compression'.*

Sticky valves.

ENGINE SURGES OR GALLOPS

Carburetor flooded.

Governor spring hooked into wrong hole in lever. *See 'Governor'.* Governor rod incorrectly adjusted. *See 'Governor'.*

ENGINE STOPS

Fuel tank empty.

Water, dirt or gum in gasoline.

Gasoline vaporized in fuel lines, due to excessive heat around engine (Vapor Lock). See *'Stopping Engine'*.

Vapor lock in fuel lines or carburetor due to using winter gas (too volatile) in hot weather.

Air vent hole in fuel tank cap plugged. Engine scored or stuck due to lack of oil.

Ignition troubles, See *'Ignition'*.

ENGINE OVERHEATS

Crankcase oil supply low. Replenish immediately.

Ignition spark timed wrong. See *'Magneto Timing'*, or *'Distributor-Battery Ignition'*.

Low grade of gasoline.

Engine overloaded.

Restricted cooling air circulation.

Part of air shroud removed from engine.

Dirt between cooling fins on cylinder head.

Engine operated in confined space where cooling air is continually recirculated.

Carbon in engine.

Dirty or incorrect grade of crankcase oil

Restricted exhaust.

Engine operated while detonating due to low octane gasoline or heavy load at low speed.

ENGINE KNOCKS

Poor grade of gasoline or of low octane rating.

Engine operating under heavy load at low speed.

Carbon or lead deposits in cylinder head.

Spark advanced too far. See *'Magneto Timing'*, or *'Battery Ignition Distributor'*.

Loose or burnt out connecting rod bearing.

Engine overheated. See previous heading.

Worn or loose piston pin.

ENGINE BACKFIRES THROUGH CARBURETOR

Water or dirt in gasoline. Poor grade of gasoline.

Engine cold.

Sticky inlet valves.

Overheated valves.

Spark plugs too hot. See *'Spark Plugs'*.

Hot carbon particles in engine.

DISASSEMBLY AND REASSEMBLY OF ENGINE

Engine repairs should be made only by an experienced mechanic. When disassembling the engine it is advisable to have several boxes available so that parts belonging to certain groups can be kept together. Capscrews of various lengths are used in the engine, therefore great care must be exercised in reassembly so that the correct screws are used in the proper places.

Tighten the capscrews and nuts of the manifold, cylinder head, gear cover, engine base, connecting rods, cylinder block, main bearing plate and the spark plugs to the specified torque readings indicated in paragraphs of reassembly relative to these parts.

With the disassembling operations, instructions on reassembling are also given, as often, it will not be necessary to disassemble the entire engine. If it is desired to disassemble the entire engine, the reassembly instructions can be looked up later under the headings of the various parts.

While the engine is partly or fully dismantled, all parts should be thoroughly cleaned. **Use all new gaskets** in reassembly and lubricate all bearing surfaces.

TESTING REBUILT ENGINE

An engine that has been completely overhauled, such as having the cylinders rebored and fitted with new pistons, rings and valves, should go through a thorough "run-in" period before any amount of load is applied to the engine.

The engine should be started and allowed to run for about one-half hour, at about 1200 to 1400 R.P.M. without load. The R.P.M. should then be increased to engine operating speed, still without load, for an additional three and one-half to four hours.

The proper "running-in" of the engine will help to establish polished bearing surfaces and proper clearances between the friction areas of the newly replaced parts.

DRAIN OIL BEFORE DISASSEMBLY

ACCESSORIES

Remove **clutch** or **reduction** unit if engine is equipped with either of these accessories.

Take off the **air cleaner** and **magneto**. If electric **starting motor**, **generator** and **distributor** were furnished, these should also be removed at this time.

Remove the muffler and disconnect the governor control, choke control, ignition switch and fuel lines.

SHEET METAL HOUSE

On power units (engines which are enclosed in a sheet metal house), the top or canopy can be removed by taking out the screws holding it to the end panels.

FRONT PANEL (Fig. 29)

Remove the air cleaner and bracket, the flywheel screen and the four screws which support the panel to side rails. The front house panel can then be removed as shown.

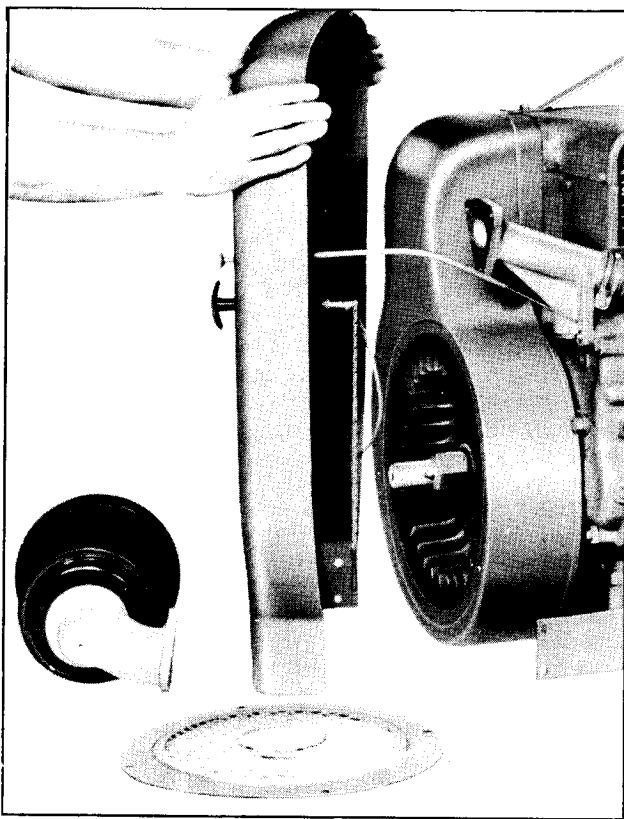

Fig. 29

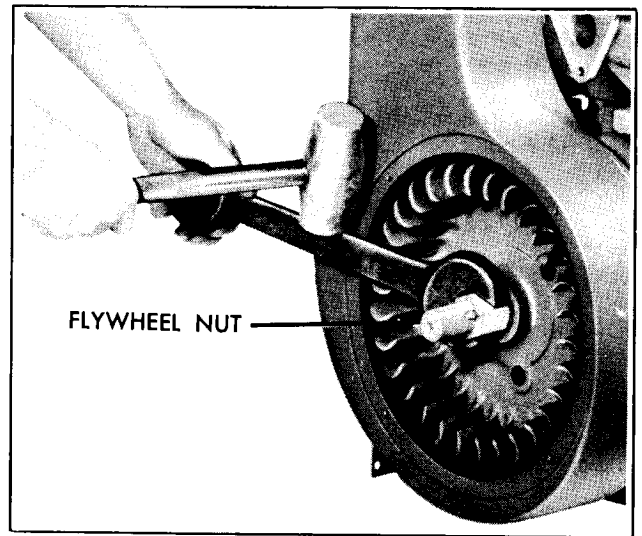

Fig. 31

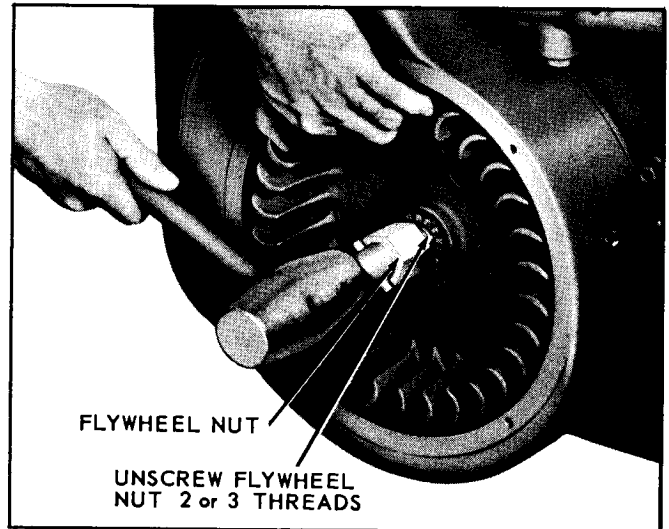

Fig. 32

FLYWHEEL (Fig. 31, Fig. 32)

Loosen the flywheel nut with a 1-3/8" open end or box wrench as shown in *Fig. 31*. **Do not** remove the flywheel nut, but unscrew it about two or three turns.

The flywheel is mounted to a taper on the crankshaft. Take a firm hold on the flywheel fins, pull outward and at the same time strike the end of the flywheel nut with a babbitt hammer. *See Fig. 32*. The flywheel will slide off the taper of the crankshaft and can be removed after the flywheel nut is removed. Striking the end of the flywheel nut instead of directly on the crankshaft will prevent serious damage to the threads at the end of the shaft. Also, do not use a hard hammer as it may ruin the crankshaft and bearings.

In reassembly, be sure the crankshaft taper and flywheel bore are clean and free from oil. Also be sure the Woodruff key is in position on the shaft and that the keyway in the flywheel is lined up accurately with the key. After mounting, seat flywheel on crankshaft taper by slipping a piece of pipe over the end of the crankshaft and against the hub of the flywheel, and striking the end of the pipe a sharp blow with a hammer. Install lockwasher, apply Loctite 271 to crankshaft threads, install flywheel nut and torque 95 to 110 foot pounds.

FLYWHEEL SHROUD (Fig. 33)

The three capscrews which mount the flywheel shroud

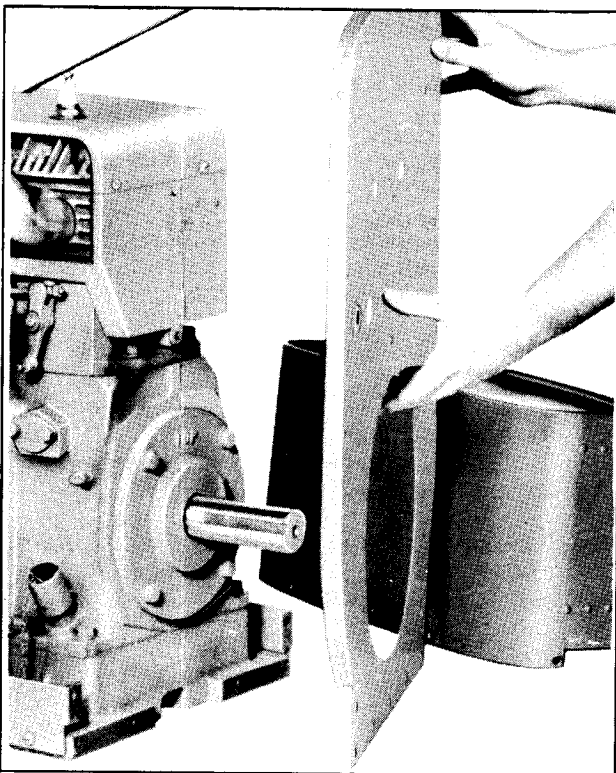

Fig. 30

REAR PANEL AND FUEL TANK (Fig. 30)

The fuel tank assembly is removed by taking out the six screws which hold it to the rear panel. The rear house panel can then be removed by taking out the screw holding it to the cylinder block, engine base and side rails.

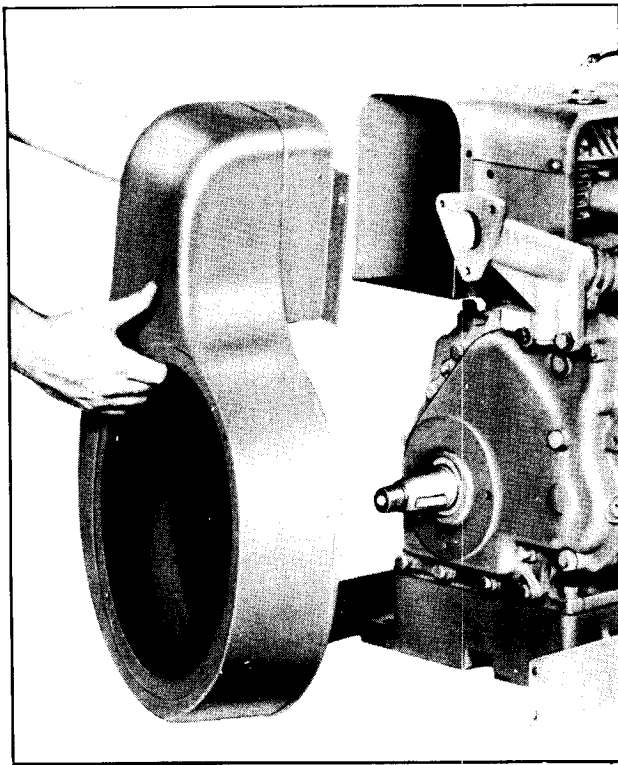

Fig. 33

to the gear cover and the six screws to the cylinder shrouding must be removed to disassemble flywheel shroud from engine.

SIDE MOUNT FUEL TANK

If it is necessary the side mount fuel tank and bracket be disassembled, loosen the tank strap screws and remove the tank. This will make the four screws for mounting the tank bracket to the crankcase and engine base accessible. Otherwise, just remove the two screws holding the bracket to the crankcase and remove the tank and bracket assembly along with the engine base when it is removed.

CARBURETOR AND MANIFOLD (Fig. 34)

Remove the cotter pin from the governor control rod and pull the rod from the control lever. Take out the two capscrews which hold the air cleaner connection bracket to the gear cover and remove the two nuts and square washers from the manifold studs. The complete carburetor, manifold and air cleaner connection bracket can be removed as a complete unit.

In reassembly; tighten the nuts for mounting the manifold to **26 foot pounds torque**. Tightening beyond specification may cause the square washers to crack.

CYLINDER HEAD

Remove the cylinder head cover, heat deflector and side shroud. If it is necessary to regrind valves or to service the pistons, rings or connecting rods, the cylinder head will have to be removed. All the cylinder head screws are plainly in view and can be easily removed. Screws of different lengths are used but these can be properly reassembled according to the various lengths of cylinder head bosses.

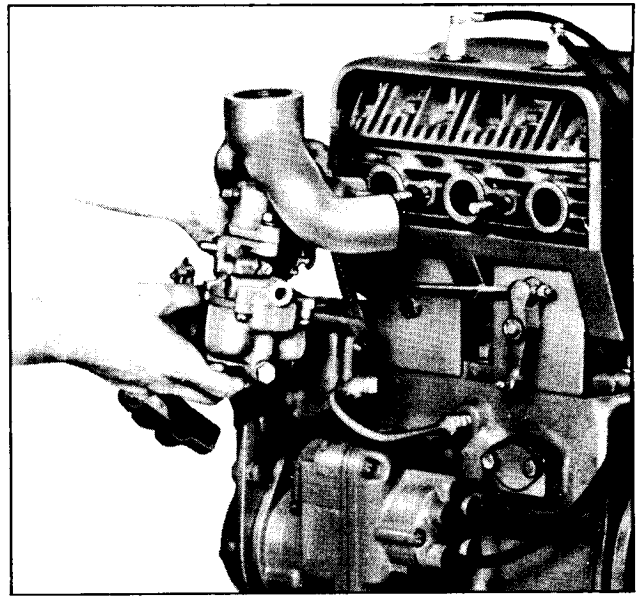

Fig. 34

In reassembly; all carbon and lead deposits should be removed. It is recommended that a new cylinder head gasket be used as the old gasket will be compressed and hard. Apply a mixture of graphite and oil on the cylinder head screws to prevent them from rusting tight against the cylinder block. Tighten cylinder head screws **22 to 24 foot pounds torque**. After complete assembly and engine is run in, retorque.

GEAR COVER (Fig. 35)

Disconnect the governor linkage and oil line. Remove governor assembly and take out gear cover mounting screws. Dowel pins remain in crankcase.

Screw a 5/16"-18 thread capscrew, having a 1-3/4" minimum length of thread, into one of the flywheel shroud mounting holes, *see Fig. 35*. Then, by lightly tapping the gear cover through the magneto mounting hole, the gear cover will come off without damage to the dowel pins.

In reassembly; tighten gear cover capscrews, **16 to 18 foot pounds torque**.

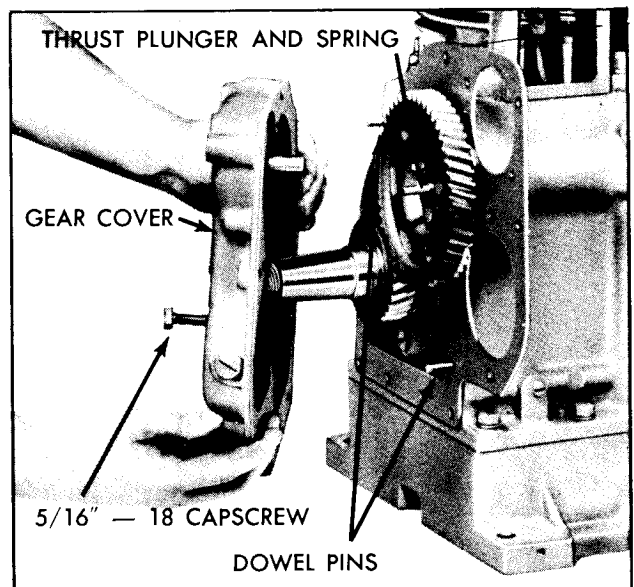

Fig. 35

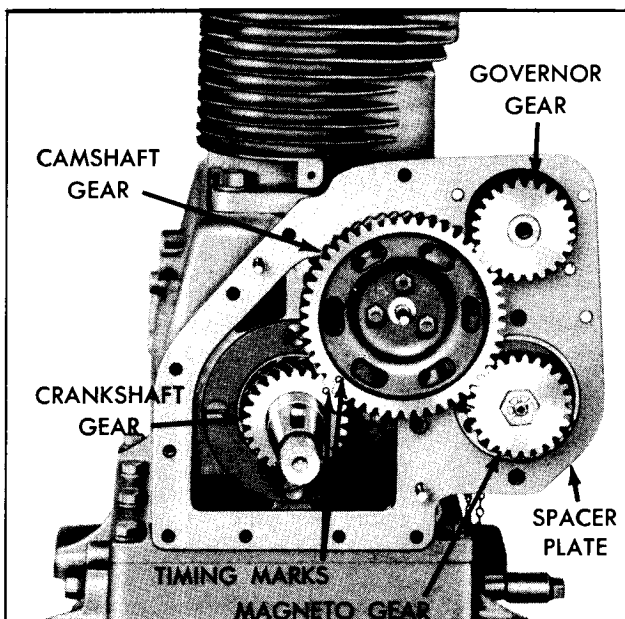

Fig. 36

GEAR TRAIN - CAMSHAFT GEAR (Fig. 36)

With the removal of gear cover and oil sling, the gear train will be exposed as shown. Remove camshaft thrust plunger and spring to prevent their being lost.

Reference can be made to Fig. 36 when assembling crankshaft and camshaft, as accurate location of the timing marks is essential for proper engine operation.

The *camshaft gear* has offset mounting holes to provide accurate assembly for valve timing. The gear can only be put on the correct way for matching up the timing mark with that of the crankshaft. After removing screws, pry gear off with a screw driver. Spacer plate can be taken off if necessary.

ENGINE BASE AND OIL PUMP (Fig. 37, Fig. 38)

Be sure oil is drained from engine base. Take out 8 capscrews which mount engine base to crankcase, then turn engine on its side and take out the two cap

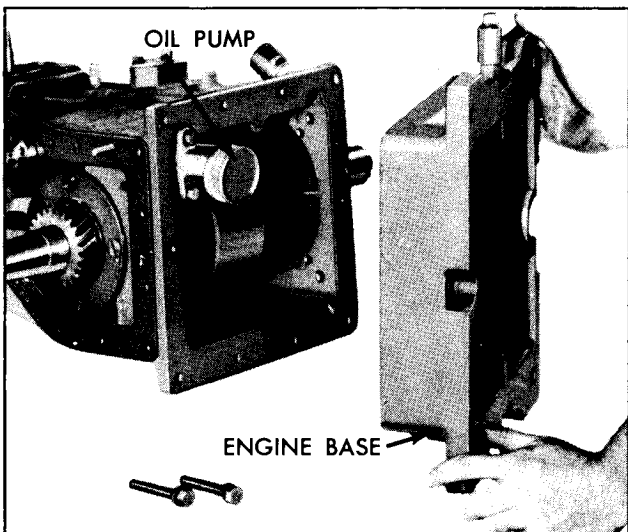

Fig. 37

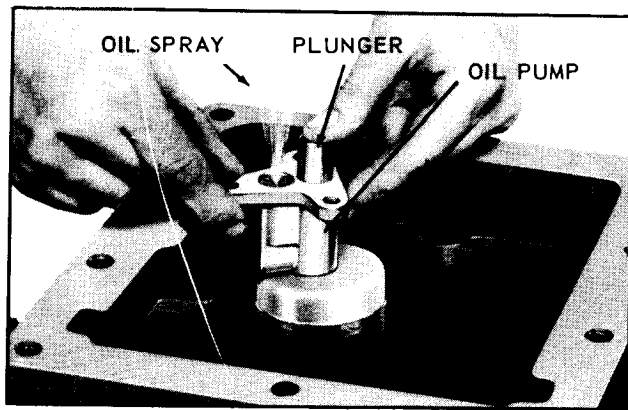

Fig. 38

screws from the bottom that hold the base to the case. Remove base as shown. *In reassembly*; tighten capscrews, 22 to 24 foot pounds torque.

NOTE: In engine models *TH* and *THD*, the oil pump is located toward the gear train end of the crankcase, as illustrated in Fig. 37, and is mounted in place with 3 capscrews. Model *TJD*, *W2-880* pump is mounted near the center of the case below the oil header tube, and is held in place with 2 capscrews.

Dismantle the oil pump by taking out capscrews which hold it to the crankcase. All parts of the pump should be thoroughly washed in solvent to remove all traces of thickened oil and sludge. The oil pump plunger should be fitted to the bore with a clearance of .003 to .005 inch. If the clearance is greater than .007 inch, the plunger and oil pump body should be replaced. Inspect the check ball seat in the bottom of the pump cylinder. This seat must be clean and must not be worn or pitted.

In reassembly; drop check ball into cylinder and tap into seat, lightly with a punch and hammer. The retainer can then be put in place and the spring and plunger inserted into the cylinder bore.

Before assembling oil pump to crankcase, fill base partially with engine oil and work pump plunger up and down, see Fig. 38, to test operation of pump.

When mounting pump, be sure plunger rod and cap are in position. Plunger cap for *TJD*, *W2-880* engine is 9/16" long, for *TH*, *THD* — 7/16" long.

CONNECTING ROD and PISTON (Fig's. 39 and 40)

By means of a 1/2" socket wrench, loosen and remove hex nuts from connecting rod bolts. Then, by tapping the ends of the bolts lightly, the connecting rod cap will break free from the bolts.

Scrape off all carbon deposits that might interfere with removal of pistons from upper end of cylinder. Turn crankshaft until piston is at top, then push connecting rod and piston assembly upward and out thru top of cylinder. Be careful not to mar the crank pin by allowing the rod bolts to strike or scrape across it.

The connecting rods have removable shell bearings and care should be taken in *reassembly* to mount them correctly. As illustrated in Fig. 39, assemble cap to rod so that *locating lug* of both bearing halves are on the same side.

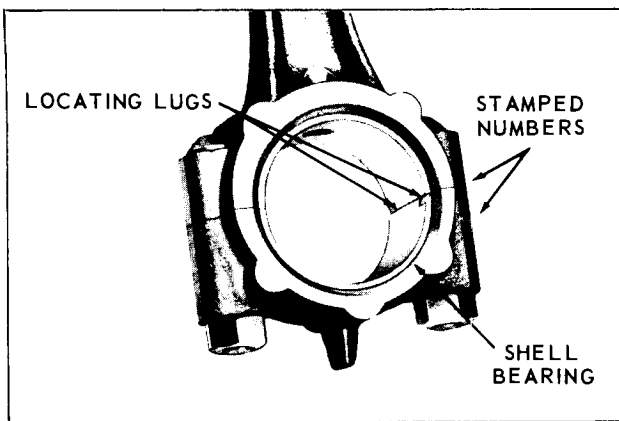

Fig. 39

PISTON TO CYLINDER AT PISTON SKIRT (THRUST FACE)		CAM-GROUND PISTON	
		Models TH, THD .0032 to .0037"	Models TJD, W2-880 .0025 to .003"
SPLIT-SKIRT PISTON, Models TH, THD		.004 to .0045"	
PISTON PIN TO CONNECTING ROD BUSHING		.0005 to .0011"	
PISTON PIN TO PISTON		.0000 to .0008" tight	
PISTON RING GAP		.010 to .020"	
		Models TH, THD	Models TJD, W2,880
PISTON RING SIDE	TOP COMP.	.002 to .004"	.002 to .004"
	2nd COMP.	.001 to .003"	—
CLEARANCE IN GROOVES	SCRAPER	.001 to .003"	.002 to .004"
	OIL RING	.002 to .004"	.0015 to .0035"
Connecting Rod to Crank Pin - Side Clearance		.014 to .023"	.009 to .014"
Connecting Rod Shell Bearing to Crank Pin Dia. (Vertical)		.0012 to .0034"	.0008 to .0029"
Connecting Rod Babbitt Bearing to Crank Pin		.0007 to .0020"	—
D - Crankshaft Pin Diameter		1.751 to 1.750"	1.8764 to 1.8756"
W - Crankshaft Pin Width		1.135 to 1.130"	1.135 to 1.130"

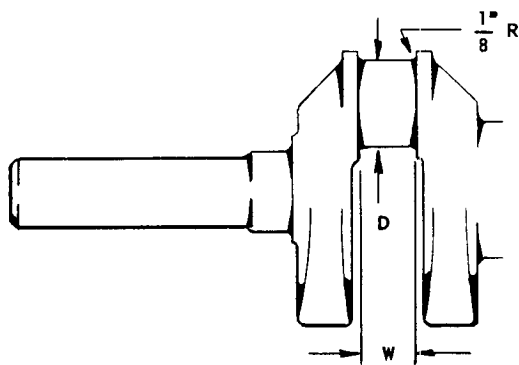

Fig. 40, PISTON, RING AND ROD CLEARANCE CHART

NOTE: Models TH and THD were originally furnished with *babbitt cast* connecting rod bearings. *Shell bearing* rods, now being used for current production engines, are interchangeable for service replacement.

TH and THD engines were also built with *split-skirt* pistons, which have since been replaced by *cam-ground* pistons. When reassembling the *split-skirt* piston, the split should be toward the manifold side of the engine. The thrust faces on the skirt of the *cam-ground* piston are 90° from the axis of the piston pin hole. Clearance between piston and cylinder is measured in the center of the thrust face at the bottom of piston skirt. Refer to chart, Fig. 40, for clearance of both split skirt and cam ground pistons.

In reassembly; be sure piston and connecting rod assemblies are put back into the same bore from which they were removed. Use a suitable ring compressor and stagger the piston ring gaps 90° apart around the piston. Oil the pistons, rings, wrist pins, rod bearings and cylinder walls before assembly.

CAUTION: Identical numbers are stamped on the side of the rod and it's matching cap. These numbers must be on the same side in assembly, see Fig. 39. Location of the *oil hole* at bottom of connecting rod cap (a recent addition), is of no significance to these models. **Install new nuts** on connecting rod bolts and **torque 22 to 28 foot pounds.**

PISTON RINGS (Fig's. 41 and 42)

In engine *Model TJD* beginning with serial No. 5219324, a *three ring* piston (chrome faced *compression ring*, tapered *scraper ring* and *oil ring*), with improved oil control characteristics, replaces the four ring pistons. *Model THD* will continue using four ring pistons.

If a ring expander tool is not available, install rings by placing the open end of the ring on piston first, as



Fig. 41

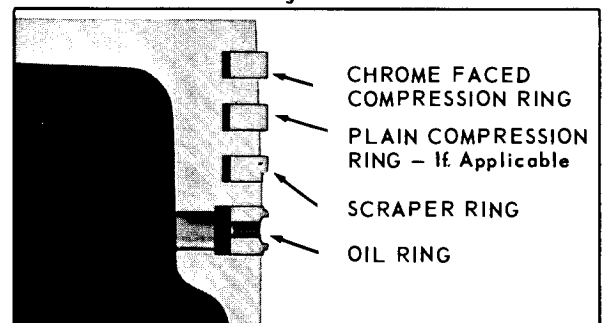

Fig. 42

shown in Fig. 41. The word **'TOP'** on compression and scraper rings indicates direction of ring placement on piston. Spread ring only far enough to slip over piston and into correct groove, being careful not to distort ring. Assemble bottom ring first and work upward, installing top ring last. The outer diameter of the top compression ring is **chrome plated**. Mount scraper ring with **scraper edge down**, otherwise oil pumping and excessive oil consumption will result. Refer to Fig. 42 for correct placement of rings. Model TJD & W2-880 engines have a **tapered face** scraper ring on the new 3 ring pistons.

CYLINDER BLOCK (Fig. 43)

Clean all dirt and foreign deposits from between fins. If cylinders are scored or worn more than **.005 inch** oversize, the block should be removed as shown, re-bored and fitted with oversize pistons and rings, at an authorized service center.

In reassembly; tighten the six cylinder block mounting nuts, **32 to 34 foot pounds torque**.

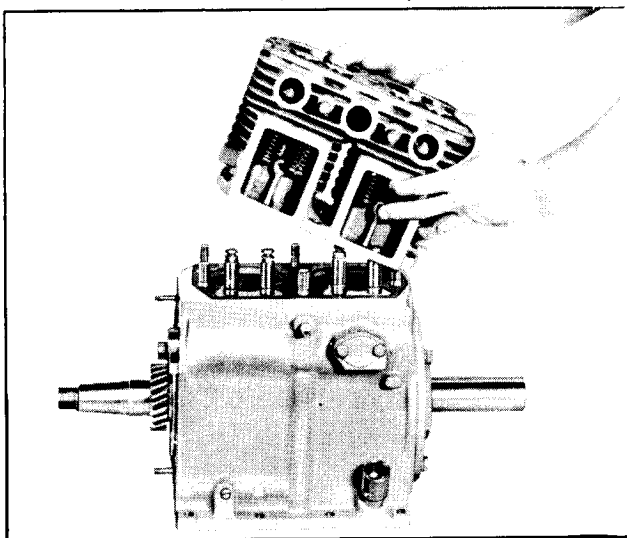

Fig. 43

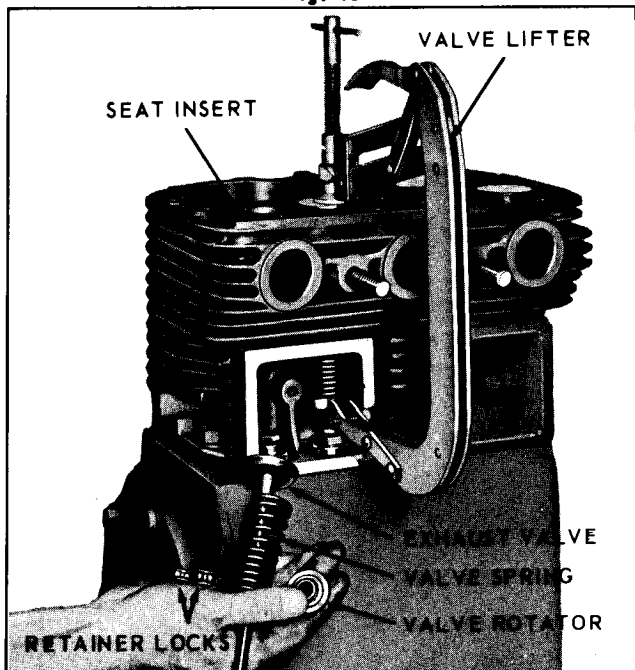

Fig. 44

VALVES and SEAT INSERTS (Fig. 44)

Replace valves that are burned or pitted. A leaky valve can usually be determined by a **'hissing'** noise in the exhaust or intake manifold when cranking the engine slowly by hand.

Remove valve tappet inspection plate and compress valve springs with a standard automotive type valve lifter as illustrated. Insert a rag in the opening at the bottom of the valve chamber so the retaining locks do not fall into the engine crankcase. Remove retaining locks, seats, springs, valves and clean these, as well as the ports and guides, of all carbon and gum deposits. Tag each valve so that in reassembly they will be mounted in the same guide they were removed from.

The **exhaust valve face** and exhaust **seat inserts** are of **stellite** material. A positive type **valve rotator** is furnished as standard equipment on the exhaust valves only. Clean and inspect operation of rotator.

The inlet and exhaust **seat inserts** can be removed, when replacement becomes necessary, by means of Wisconsin Motor **DF-66-A** insert puller.

Valve grinding should be done by an authorized service dealer, since he has the necessary equipment and experience to do a reputable job.

Before grinding valves, inspect valve guides for possible replacement. Refer to *Valve Guide* paragraph. The valve face is ground at **45°** to the vertical center line of the valve stem and the valve seat insert should also be ground at a **45°** angle. *After grinding,* lap valves in place until a uniform ring will show entirely around the face of the valve. Clean valves, and wash block thoroughly with a hot solution of soap and water. Wipe cylinder walls with clean lint free rags and light engine oil, especially if cylinders were re-bored and honed.

Valve guides in the cylinder block are replaceable. The valve stem has a clearance of **.003** to **.005"** in the guide. When the clearance becomes **.007"**, the guide should be driven out and a new guide pressed in place. Use Wisconsin Motor **DF-72** driver.

CRANKSHAFT and MAIN BEARING PLATE (Fig. 45)

To remove the crankshaft, first remove oil slinger from the flywheel end of shaft, and then take out the four capscrews holding main bearing plate in place at the take-off end. The main bearing plate can then be pried off and the crankshaft removed from that end of the crankcase as shown.

In reassembly; use same quantity and thickness of new bearing plate gaskets and shims as were removed, since these are necessary to give the proper end play for the tapered roller crankshaft bearings. **End play** should be **.001** to **.005** inch when engine is **cold**. There is practically no wear in these tapered roller bearings so that readjustment is seldom necessary.

CAUTION: When assembling crankshaft, the **timing**

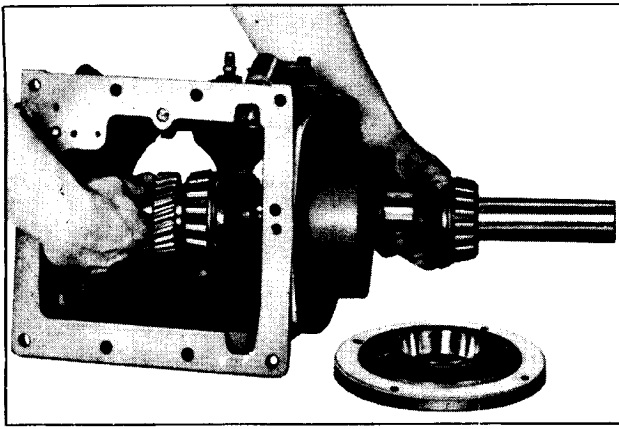

Fig. 45

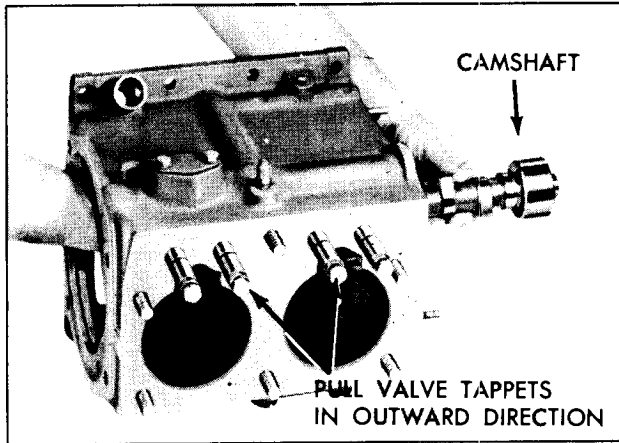

Fig. 46

marks on the crankshaft gear and camshaft gear must match up, as shown in Fig. 36, otherwise engine will not operate properly or if timing is off considerably, engine will not run at all.

Main bearing plate does not require a particular mounting position. Cast arrow on outside face (indicating crankshaft rotation), is usually located at the top. Tighten main bearing plate capscrews, 20 to 22 foot pounds torque.

CAMSHAFT and VALVE TAPPETS (Fig. 46)

To prevent tappets from falling out and becoming damaged when camshaft is removed, turn crankcase over on its side as shown. Push tappets inward to clear cam lobes and remove camshaft.

Remove tappets; check face for scuffing and inspect body for wear. Body diameter of .624/.623" has a clearance of .0005 to .0025" in guide hole.

In reassembly; lubricate tappets and insert them in

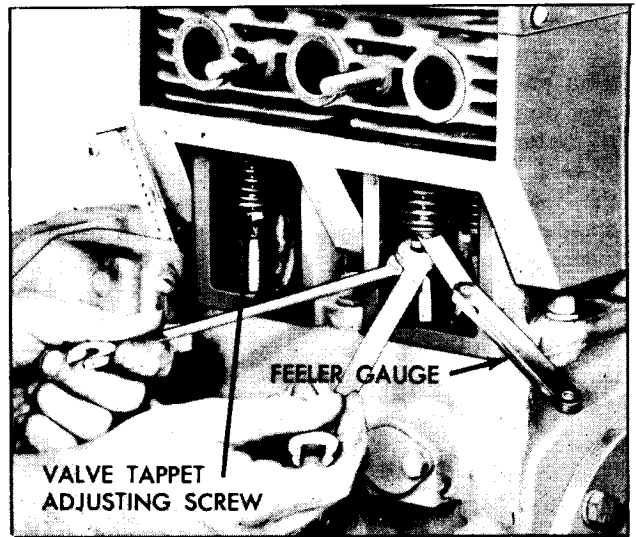

Fig. 47

crankcase before camshaft is assembled. Be sure thrust plunger and spring are in place at end of camshaft, after gear is mounted and just before mounting gear cover.

OIL SPRAY NOZZLE

The oil spray nozzle is installed so that both metered holes can be seen when looking directly into the bottom of the crankcase. When positioned correctly, the flats on the hex body of the nozzle will be parallel with the top and bottom machined surfaces of the crankcase. The end of the spray nozzle should extend about 1/2 inches from the boss it is screwed into, or so that the restricted discharge holes line up with the crankshaft centerline when it is installed. See oil spray nozzle, Fig. 3 and Fig. 4.

VALVE TAPPET ADJUSTMENT (Fig. 47)

If engine was completely dismantled, the tappets can be adjusted after cylinder block assembly is mounted and before mounting the cylinder head and manifold.

With tappets in their lowest position (valves completely closed) and engine cold, the clearance between valve stem and tappet adjusting screw should be:

Intake - .008"
Exhaust - .016"

Adjust as shown by means of two 1/2 inch tappet wrenches.

After completing reassembly and engine is tuned up; operate engine in accordance with "Testing Rebuilt Engine" procedure, outlined at the beginning of the disassembly and reassembly section of this manual.

LP-62 series FUEL PUMP

SERVICE INSTRUCTIONS

For single and two cylinder engine models

PART NO.	ENGINE USED ON
LP62A	THD, TJD
LP62B	ACN, BKN, AENL
LP62D	AGND
LP62E	S-7D
LP62F	S-10D, S-12D, S-14D
LP62G	S-8D, TRA-10D, TRA-12D

The fuel pump, like all other parts of the engine, is subject to wear and you will find that any time after 500 hours of use, its efficiency will gradually decrease. This is indicated by the engines faltering at high speeds or when heavy loads are suddenly applied. The pump can easily be restored to its normal efficiency by the installation of a Wisconsin LQ-51 Diaphragm Kit.

1. Disconnect fuel lines from pump and remove fuel strainer if mounted to pump. Remove fuel pump from engine housing by taking out the two mounting screws.
2. File a groove across a point at the union of castings (9 and 10). This is a positive location of the fuel INLET and OUTLET positions when reassembling. Remove four head to bracket screws (12) and remove fuel head (10).
3. Turn fuel head (10) over, remove and discard both valve assemblies, noting their positions.
4. Clean fuel head thoroughly with kerosene or diesel fuel and a fine wire brush.

5. Hold fuel head (10), with diaphragm surface up, place two valve gaskets (4) into cavities where valves were removed. Press valve assemblies (5) in evenly without distortion, and stake in place.
6. Set fuel head assembly aside and proceed to rebuild lower diaphragm section.
7. Insert the end of a small screw driver into the coils of rocker arm spring (11), remove and save.
8. Hold mounting bracket (9) in the left hand, with the rocker arm toward your body and the thumb nail on the end of link (8). With the heel of right hand on diaphragm (2), compress the diaphragm spring (3), and at the same time turn in a clockwise direction 90°. This will unhook the diaphragm from link (8) so it can be removed.
9. Clean the mounting bracket (9) with kerosene or diesel fuel and a fine wire brush.
10. Place the new diaphragm operating spring (3) into bracket (9). Repeat in reverse order paragraph eight, using the new diaphragm. Replace rocker arm spring (11) removed in paragraph seven.
11. Mount this assembly back on the engine in the position from which it was removed, using the new flange gasket (13), which is the last piece of the repair kit.
12. Crank the engine over to a position where the diaphragm (2) is laying flat on the mounting bracket (9). Place the fuel head (10) back in position so that the indicating marks of step one are in line, and start the four head screws approximately three turns. Again, crank the engine over to a position where diaphragm (2) is pulled down into mounting bracket (9) to its lowest position. Securely tighten the four head screws (12).
13. Mount fuel strainer to fuel pump, if applicable, and connect fuel lines.

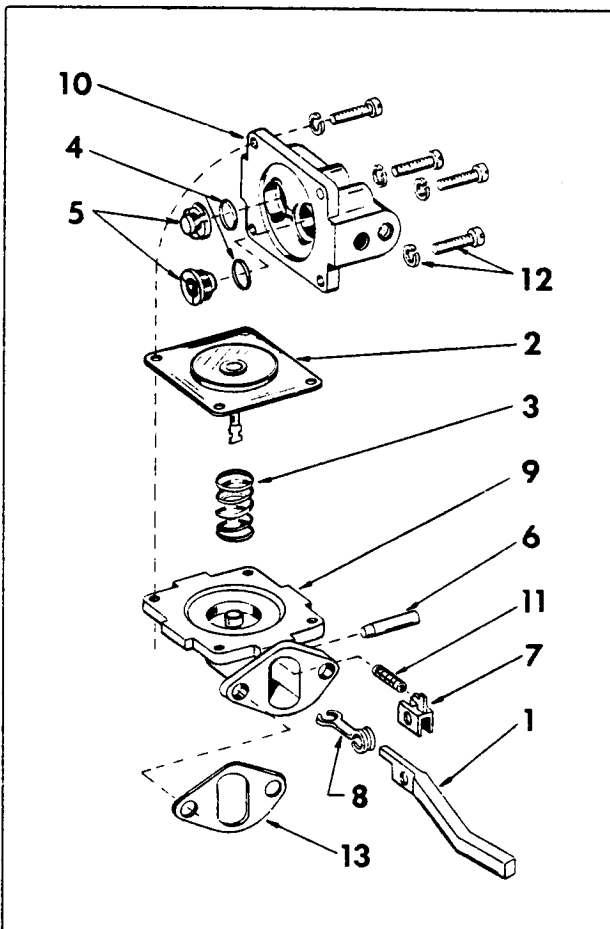

NOTE: The LQ-51 Diaphragm Kit and the parts included therein, which are identified by an asterisk (*), are the only parts of the fuel pump available for service.

Ref. No.	Description	No. Req.
1	ROCKER ARM	1
* 2	DIAPHRAGM ASSEMBLY	1
* 3	DIAPHRAGM SPRING	1
* 4	VALVE GASKETS	2
* 5	VALVE and CAGE ASSEMBLY	2
6	PIN for rocker arm	1
7	SPRING CLIP for rocker arm	1
8	LINK for diaphragm spring	1
9	MOUNTING BRACKET	1
10	FUEL HEAD	1
11	SPRING for rocker arm	1
12	SCREW and WASHER for head mounting	4
*13	GASKET for mounting flange	1

FLYWHEEL ALTERNATOR

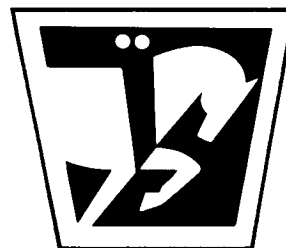

with solid state regulation

12 Volt – 10 amp and 25 amp Systems For
WISCONSIN Single, Two and Four Cylinder Engine Models

DESCRIPTION of Change

Beginning with engine serial No. 5188288, a new *two module* flywheel alternator system replaces the previously furnished three module system, that included an isolation diode module, and the two unit system without the isolation diode.

The *isolation diode* module was incorporated into the old system to eliminate battery discharge problems during shut down, cranking and idling.

INTERCHANGEABILITY

The *Regulator module* was not changed and is completely interchangeable between the new and old systems. The *Rectifier module* and *Stator assembly* have been modified to incorporate the advantages of an isolation diode without adding a third module. These new parts are *not* interchangeable with the old unless both rectifier and stator are replaced simultaneously. The new system has a *three prong* plug connector between the rectifier and stator – the old system has a two prong connector.

DESCRIPTION and OPERATION

This flywheel alternator is of the permanent magnet type and has *no brushes, commutator, belts or adjustments*. A series of coils (stator) is mounted to the engine gear cover, and the magnetic flux is provided by a permanent magnet in the flywheel which rotates around these stationary coils. Only four components make up this light weight space saving system; a *flywheel* with magnetic rotor, *stator*, *rectifier* module and *regulator* module.

The *center-tap* rectifier arrangement prevents damage to the alternator system when arc welding, because the winding acts as a choke and its inductance prevents the transient voltage from damaging the diodes.

Since the physical appearance of both 10 amp and 25 amp alternator systems are very similar, the *25 amp*

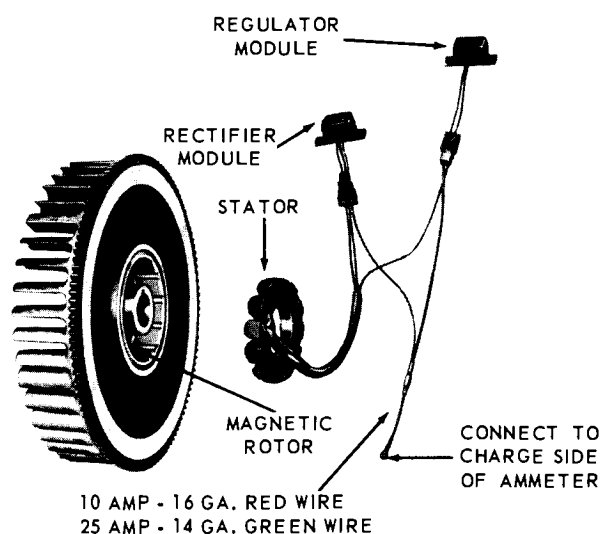

unit can be distinguished from the *10 amp unit* by the ammeter calibrations, and by a *14 gage green wire* in place of a *16 gage red wire*, from the ammeter to the stator-regulator connector.

PRECAUTIONS to be exercised in the use of this flywheel alternator:

1. **Do Not** reverse battery connections. This is for a *negative ground* system only.
2. Connect booster batteries properly – positive to positive and negative to negative.
3. **Do Not** polarize the alternator.
4. **Do Not** ground any wires from stator or modules which terminate at connectors.
5. **Do Not** operate engine with battery disconnected from system.
6. Disconnect at least one battery lead if a battery charger is used.

WIRING CIRCUIT

The fool-proof type connectors used prevent incorrect wiring from the stator to the rectifier and regulator modules. To disconnect plugs, squeeze outer ends of receptical and pull apart.

The rectifier is insulated from ground, but the stator and regulator module are grounded to the engine thru their mounting surface. The regulator module therefore should not be removed and mounted at some remote location. This is a *negative ground circuit*. Connect ground strap from negative post of battery to starting motor flange, or good clean grounding surface on engine.

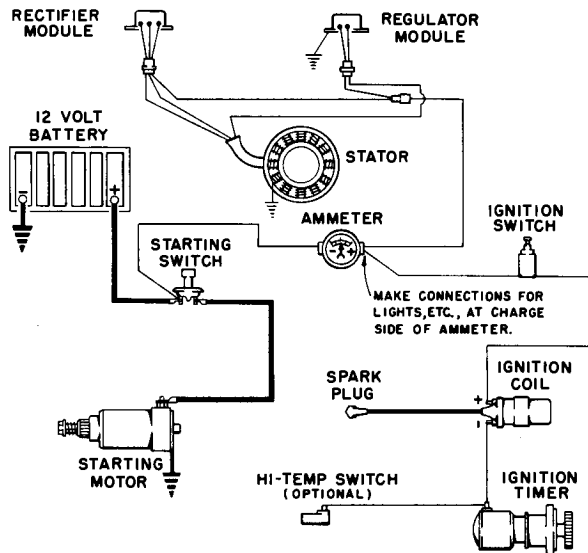

WIRING DIAGRAM
For Single Cylinder Models

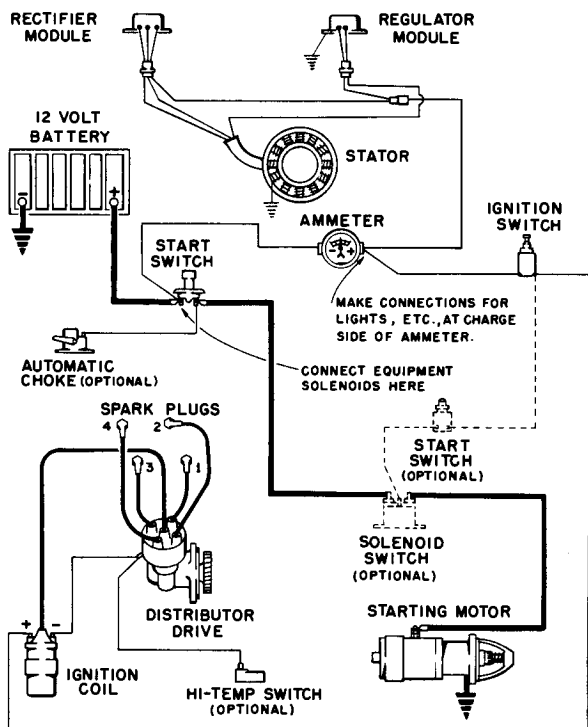

WIRING DIAGRAM
For Two and Four Cylinder Models

SERVICE PROCEDURE:

Prior to electrical testing, a thorough visual inspection should be made to eliminate conditions that may be interpreted as a defected alternator. Examine leads for broken or loose connections, and make sure modules are securely mounted. The *regulator module* must be mounted to a metal surface for grounding purposes, while the *rectifier module*, although insulated from ground, should be securely mounted for heat dissipation. The mounting surfaces must be clean and free of contaminants, oil, grease, etc. When assured that the problem is with the alternator, follow the tests outlined in 'Trouble Shooting'.

TROUBLE SHOOTING

10 and 25 amp Flywheel Alternator

Problem: Battery Overcharge	Possible Cause & Remedy
Test 1.0 With engine running at full RPM, check battery voltage w/ DC Voltmeter.	
1.1 If voltage is over 15.0	1.1 Regulator not functioning properly. Replace module.
1.2 If voltage is under 15	1.2 Alternator functioning properly. Check battery condition.

Problem: Low/No Charge	Possible Cause & Remedy
Test 1.0 With engine running at full RPM, check battery voltage w/ DC meter. If voltage is greater than 14 volts, place * load on battery to reduce voltage below 14 volts.	
1.1 If the charge rate increases -	1.1 Alternator functioning properly. Battery was fully charged.
1.2 If the charge rate does not increase -	1.2 Proceed with Test 2.0.
* Place as many 12 volt light bulbs across battery as required to reduce voltage below 14 volts. A carbonpile resistor may be used in place of bulbs.	

Problem: Low/No Charge	Possible Cause & Remedy
<p>Test 2.0 Conditions and procedure the same as Test 1.0 except the regulator module is disconnected.</p> <p>2.1 If the charge rate increases –</p> <p>2.2 If the charge rate does not increase–</p> <p>Test 3.0 Test conditions and procedure the same as 1.0 except with new rectifier module plugged in.</p> <p>3.1 If the charge rate increases –</p> <p>3.2 If the charge rate does not increase–</p> <p>Test 4.0 With engine stopped, unplug all connectors between modules and stator. Start engine and run at 2400 RPM. With AC voltmeter check voltage between each of the black stator leads and ground.</p> <p>4.1 If one of the two voltages is zero or they are over 10% apart –</p>	<p>2.1 Regulator was at fault. Replace regulator module.</p> <p>2.2 Regulator is not at fault. Continue with Test 3.0.</p> <p>3.1 Rectifier module at fault. Permanently install new rectifier module.</p> <p>3.2 Continue with Test 4.0.</p> <p>4.1 The stator is faulty and should be replaced.</p>

Further testing can be done on the component level with the engine stopped, and the stator and module connections including output lead uncoupled.

TO CHECK STATOR

Use an ohmmeter and check continuity as follows:

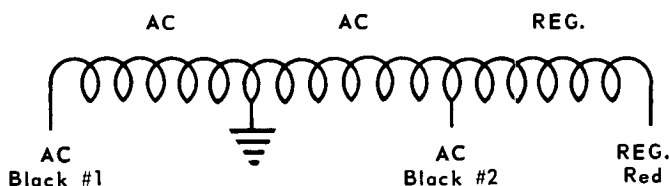

NOTE: Wire numbers indicated for probe connections are for convenience only and are not indicated on the connectors.

For 10 amp unit STATOR

METER PROBE CONNECTIONS		METER VALUE	REPLACE STATOR
+	-		
Black #1 to Black #2		APPROX. 2.0 ohms	0 Indicates Short Circuit. ∞ Indicates Open Circuit.
Black #1 to Eng. Gnd.		1.0 ohm	
Black #2 to Eng. Gnd.		1.0 ohm	
Black #1 to Red		3.0 ohms	
		1.0 ohm	

For 25 amp unit STATOR

METER PROBE CONNECTIONS		METER VALUE	REPLACE STATOR
+	-		
Black #1 to Black #2		APPROX. 0.40 ohm	∞ Indicates Open Circuit.
Black #1 to Eng. Gnd.		0.20 ohm	
Black #2 to Eng. Gnd.		0.20 ohm	
Black #1 to Red		3.20 ohms	
Black #2 to Red		2.80 ohms	

STATOR IDENTIFICATION:

10 amp – 3/8" wide flange 25 amp – 5/8" wide flange

TO CHECK RECTIFIER MODULE, Part No. YJ-68

The same module is used for both the 10 amp and 25 amp systems. It can be distinguished from the regulator by the three lead wires instead of two and the identification decal. Use an ohmmeter and *static check* continuity as follows:

METER PROBE CONNECTIONS		METER INDICATION
+	-	
White lead to Black #1		No Continuity
Black #1 to White lead		Continuity
White lead to Black #2		No Continuity
Black #2 to White lead		Continuity

Note: Continuity shall be in one direction only. If readings are not as indicated, replace module.

TO CHECK REGULATOR MODULE, Part No. YJ-60

The same Regulator module is used for both the 10 amp and 25 amp systems. Use an Ohmmeter and *static check* as follows:

METER PROBE CONNECTIONS		METER INDICATION	REPLACE MODULE
+	-		
Red to Eng. Gnd.		No Continuity	Continuity
Eng. Gnd. to Red		Continuity	
Red to Black			No Continuity
Black to Red			
Black to Eng. Gnd.			
Eng. Gnd. to Black		Continuity	

AMP OUTPUT regulated by engine speed

MODEL	MAXIMUM ENGINE SPEED	10 AMP SYSTEM	25 AMP SYSTEM
S-12D, S-14D AENL, TJD	3600 RPM	10 amps	25 amps
AGND	3200 RPM	10 amps	23 amps
VH4D	2800 RPM	9 amps	20 amps
VG4D	2400 RPM	8 amps	17 amps

CARBURETOR for TJD

SERVICE INSTRUCTIONS

ZENITH MODEL 68-7

WISCONSIN L-63 SERIES

The Zenith 68-7 Series carburetor is of an up-draft single venturi design with a 1" S.A.E. barrel size and a 7/8" S.A.E. flange. The carburetors are made with selective fuel inlet, and with or without a main jet adjustment. These carburetors are "balanced" and "sealed", and the semi-concentric fuel bowl allows operation to quite extreme angles without flooding or starving.

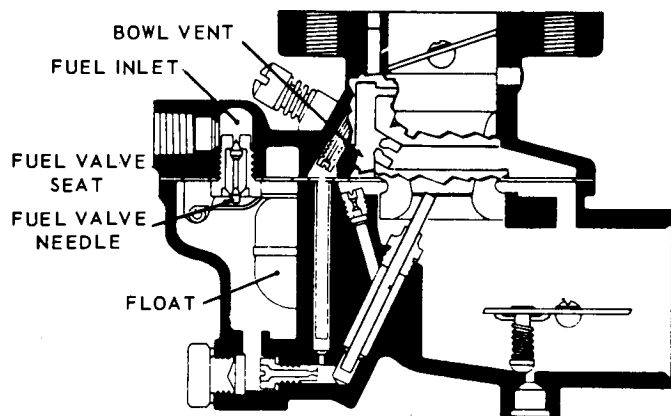

Fig. 1

Fuel supply system, Fig. 1, is made up of a threaded fuel inlet, fuel valve seat, fuel valve needle, float and fuel bowl. Fuel travels through the fuel valve seat and passes around the fuel valve and into the fuel bowl. The level of the fuel in the fuel chamber is regulated by the float through its control of the fuel valve. The fuel valve does not open and close alternately but assumes an opening, regulated by the float, sufficient to maintain a proper level in the fuel chamber equal to the demand of the engine according to its speed and load.

The inside bowl vent as illustrated by the passage originating in the air intake and continuing through to the fuel bowl, is a method of venting the fuel bowl to maintain proper air fuel mixtures even though the air cleaner may become restricted. This balancing is frequently referred to as an "inside bowl vent".

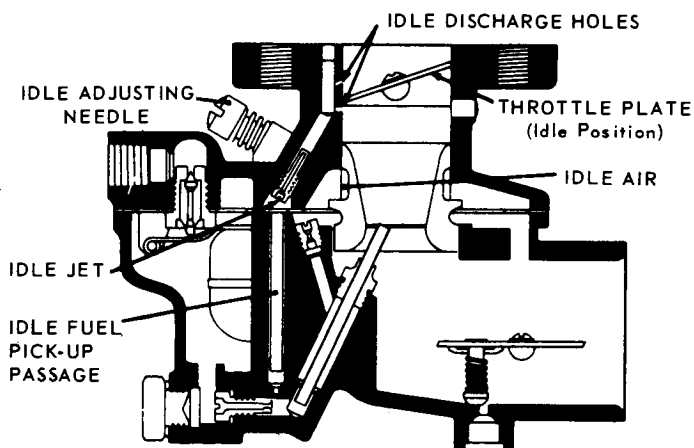

Fig. 2

Idle system, Fig. 2, consists of two idle discharge holes, idle air passage, idle adjusting needle, idle jet, and fuel pick-up passage. The fuel for idle is supplied through the main jet to a well directly below the main discharge jet. The pick-up passage is connected to this well by a restricted drilling at the bottom of this passage. The fuel travels through this channel to the idle jet calibration. The air for the idle mixture originates back of (or from behind) the main venturi. The position of the idle adjusting

needle in this passage controls the suction on the idle jet and thereby the idle mixture. Turning the needle in closer to its seat results in a greater suction with a smaller amount of air and therefore a richer mixture. Turning the needle out away from its seat increases the amount of air and reduces the suction, and a leaner mixture is delivered. The fuel is atomized and mixed with the air in the passage leading to the discharge holes and enters the air stream at this point.

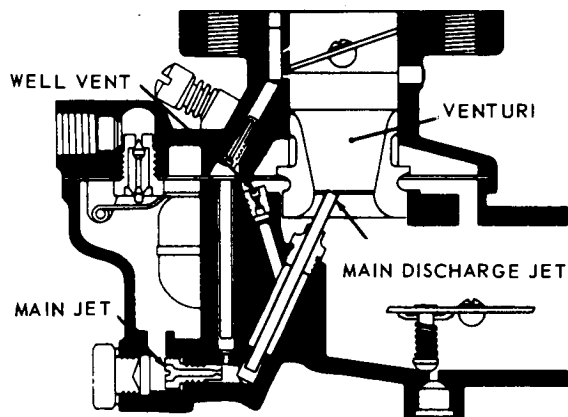

Fig. 3

High speed system, Fig. 3, controls the fuel mixture at part throttle speeds and at wide open throttle. This system consists of a venturi, controlling the maximum volume of air admitted into the engine; the main jet, which regulates the flow of fuel from the float chamber to the main discharge jet; the well vent, which maintains uniform mixture ratio under changing suction and engine speeds; and a main discharge jet, which delivers the fuel into the air stream.

The main jet controls the fuel delivery during part throttle range from about one-quarter to full throttle opening. To maintain a proper mixture, a small amount of air is admitted through the well into the discharge jet through air bleed holes in the discharge jet at a point below the level of fuel in the metering well.

The passage of fuel through the high speed system is not a complicated process. The fuel flows from the fuel chamber through the main jet and into the main discharge jet where it is mixed with air admitted by the well vent, and the air-fuel mixture is then discharged into the air stream of the carburetor.

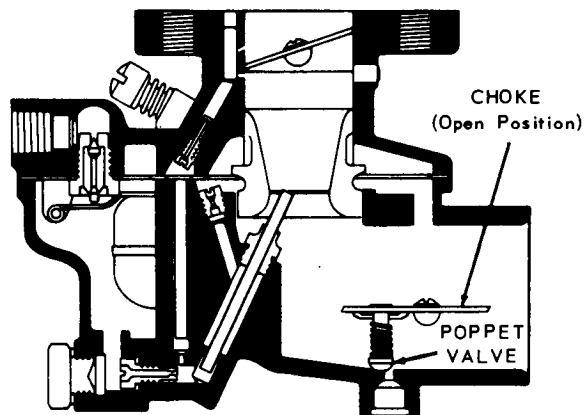

Fig. 4

Choke system, Fig. 4, consists of a valve mounted on a shaft located in the air entrance and operated externally by a lever mounted on the shaft. The choke valve is used to restrict the air entering the carburetor. This increases the suction on the jets

when starting the engine. The choke valve is of a "semi-automatic" type, having a poppet valve incorporated in its design, which is controlled by a spring. The poppet valve opens automatically when the engine starts and admits air to avoid **over-choking** or **flooding** of the engine. The mixture required for starting is considerably richer than that needed to develop power at normal temperatures. As the engine fires and speed and suction are increased, the mixture ratio must be rapidly reduced. This change is accomplished through adjustment of the choke valve and the automatic opening of the poppet valve to admit more air when the engine fires.

FLOAT SETTING, Fig. 5

If float position is not to the dimension shown, use a long nose pliers and bend lever close to float body, to obtain correct float setting.

FUEL LEVEL

The liquid level in float chamber is $17/32$ to $19/32$ inch below top of float bowl. This level was established with a #35 fuel valve seat at $1\frac{1}{2}$ p.s.i. and a sight tube approximately $1/4$ to $9/32$ inch i.d.

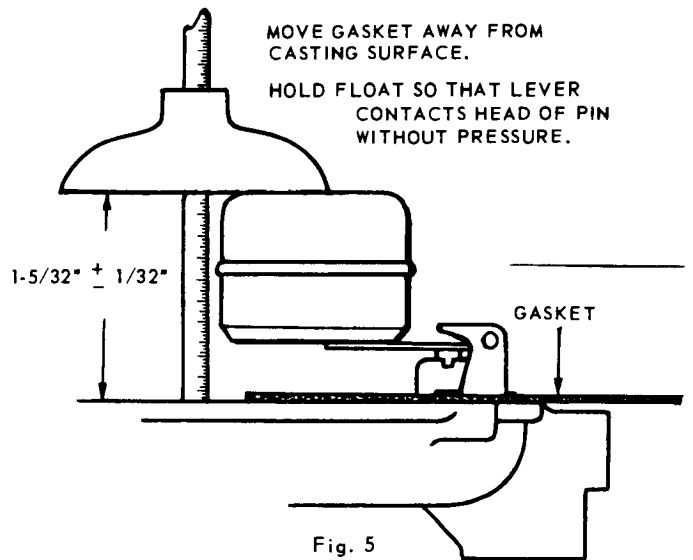

WALBRO CARBURETOR Model LUB

WISCONSIN
L 108 etc
L 111 etc

SERVICE INSTRUCTIONS For WISCONSIN Engine Model TJD

OPERATION, Fig. 1

Fuel is gravity fed or pumped through the gas line from the tank to Inlet fitting (1), through inlet needle Valve seat (2) and into the fuel bowl. As the level in fuel bowl increases, the Float (3) rises, shutting off the fuel supply by forcing needle valve into Valve seat (2). As fuel is being consumed, the float drops and allows additional fuel to enter the bowl through the valve seat. Internal Air vent (7) provides clean air to balance atmospheric pressure in fuel bowl.

WHEN STARTING; the Choke valve (5) is closed and the Throttle valve (10) is wide open causing an abnormally high suction. This high vacuum demand draws fuel and air from both idle and main systems for ease in cold starts.

Fuel from the bowl enters the Main metering jet (4), then up through Main nozzle (9) where it combines with air from Nozzle well air-vent (6). This mixture passes thru Venturi (8) and blends with fuel/air mixture from Air vent (15) and Idle holes (11) and (12) to provide a highly volatile rich mixture for starting.

AT IDLE SPEEDS; the Throttle valve (10) remains closed, exposing only the Idle hole (11) from which a fuel/air mixture is drawn. Air volume is closed off up to the idle hole by the throttle valve as the Choke valve (5) is now open. The Idle adjusting needle (14) regulates the amount of fuel/air mixture to the Idle hole (11), from Idle air vent (15) and Idle fuel channel (16), to meet various engine operating conditions.

AT HIGH SPEED, or full throttle operation; gradual acceleration is obtained when the Throttle valve (10) is partially opened allowing additional fuel/air mixture from the Idle hole (11) and Part throttle hole (12) to enter the engine combustion chamber, causing the engine to run faster. As the throttle valve opening is increased and the engine demands a greater fuel/air volume, the Nozzle (9) begins to satisfy this requirement beyond the idle hole and part throttle hole capacities.

After the acceleration assist from the idle system; at full throttle the complete idle circuit is reversed, as air only, in place of the fuel/air mixture, is drawn through the Idle holes (11), (12), and Channel (16), to Nozzle (9), where it is blended with fuel drawn from float chamber thru Jet (4).

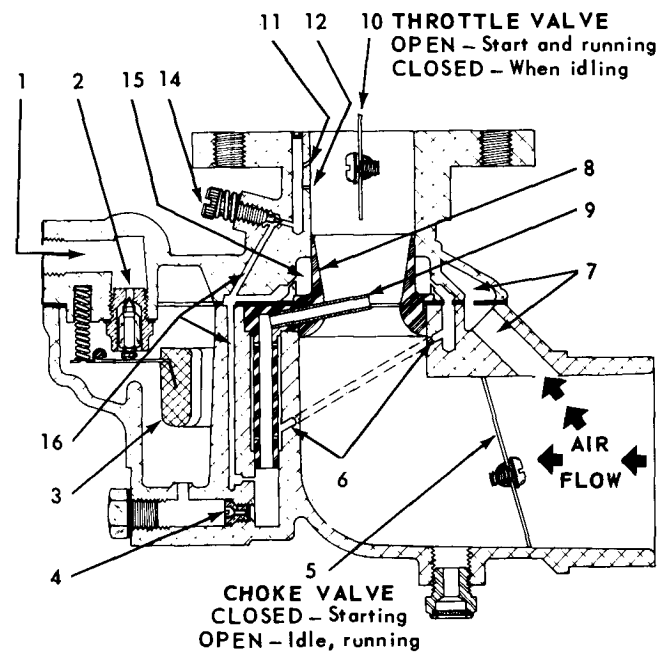

Fig. 1

CARBURETOR TROUBLES CAUSES AND REMEDIES

Dirt is the major cause of field service carburetor problems. An adequate Fuel Filter must be used between the tank and carburetor, and should be serviced frequently. Service Air Filter daily - Keep carburetor and linkage free of dirt.

FUEL LEAKS FROM CARBURETOR

Float level set too high: Remove bowl, invert carburetor and set float. See Fig. 2 and Float Setting Instructions, page 2.

Dirt under inlet needle valve: Remove inlet valve, clean seat by rinsing in mild solvent or clean fuel, and blow off with compressed air.

Bowl vent plugged: Remove bowl and blow clean with compressed air.

Collapsed float, caused by blowing assembled carburetor with compressed air: Replace float.

Carburetor gummed from storage - float stuck: Remove fuel bowl and clean.

ENGINE SMOKES AND RUNS RICH

Dirty air filter: Clean per instructions.

Improper adjustment: Set Idle Needle $1 \pm 1/8$ turns open from seat. Refer to Adjustment Instruction, page 2.

Bowl to body gasket leaks: Tighten securely, or replace.

Air vent in carburetor plugged: Remove fuel bowl and idle needle. Clean air and idle channels thoroughly with compressed air.

ENGINE RUNS LEAN

Improper adjustment: Set Idle Needle $1 \pm 1/8$ turns open from seat. Refer to Adjustment Instructions, page 2.

Idle holes plugged. Dirt in fuel delivery channels: Remove fuel bowl and idle needle. Clean thoroughly with compressed air.

Low fuel level: See Fig. 2 and Float Setting Instructions, page 2.

Fuel filter plugged: Remove and clean.

ENGINE STARTS HARD

Improper adjustment: Set Idle Needle $1 \pm 1/8$ turns open from seat. Refer to Adjustment Instructions, page 2.

No fuel in carburetor: Check carburetor drain plug. Clean tank, filter and carburetor. Check fuel lines for obstructions, and test fuel pump.

Choke valve not closing: Check linkage for proper travel.

GOVERNOR SURGE

Governor sticking: Check linkage for binding.

Throttle shaft and valve binding: Remove and replace shaft if worn. Clean carburetor body and reassemble throttle shaft.

DISASSEMBLY

Before disassembling: Clean outside of carburetor from all foreign material.

IMPORTANT: When cleaning a completely assembled carburetor do not blow with compressed air, you may collapse the float.

For a complete disassembly, follow the sequence of part reference numbers in the carburetor exploded view, Fig. 3. **Nozzle Ref. 9, Fig. 1 is not removable.**

IMPORTANT: Before removing Throttle and Choke levers, note their position and location. Optional mounting is available and may differ from exploded view illustration.

CLEANING

Wash all parts in a mild solvent or fuel. Blow air through orifices (holes) and channels in throttle body and fuel bowl. **Do not probe with any sharp tools which might damage small metering holes.**

REASSEMBLY

Replace all worn or damaged parts – use all new gaskets. **Note;** Body Gasket (18) is put on before float is assembled, and round opening in gasket fits into groove of Venturi (11).

Be sure that Notch in Venturi is facing toward float needle valve – this is clearance for Main nozzle in throttle body.

Assemble Throttle Valve (8) and Choke Valve (25) with part numbers facing to the outside, when valves are in the closed position.

IMPORTANT: Be careful in tightening brass screws and fittings, so as not to strip threads and screw driver slots.

Tighten firmly but not excessively.

Valve Seat (16) – 40 to 50 inch pounds torque
Main Jet (22) – 50 to 60 inch pounds torque

FLOAT SETTING, Fig. 2

With fuel bowl removed and float assembly in place, turn throttle body upside down so that float assembly is on top. Check float height with a depth gauge. Setting should be 1.010 inch \pm .020 above bowl gasket. If necessary, bend float arm (at float), to obtain correct height.

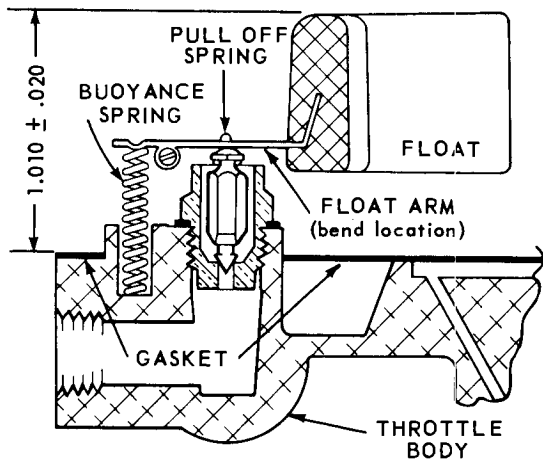

Fig. 2 FLOAT SETTING

ADJUSTMENTS, Fig. 1

Turn Idle speed screw (5), Fig. 3, in until throttle valve is slightly open. With engine warmed up and running, turn adjusting screw in or out as required to obtain desired low idle speed (1000 to 1200 r.p.m.).

The Idle adjusting needle (14) should be seated lightly (clockwise), then backed out $1 \pm 1/8$ turns as a preliminary setting. With engine warmed up and running at about 1200 R.P.M., fine tune idle mixture for smooth steady running.

The Main Metering Jet (4), for high speed operation is fixed (not adjustable), as standard equipment, and used in the majority of engine applications. However, an Adjustable Jet carburetor is available, and the High Speed Adjustment is made by means of the Needle Assembly, Item 22A of Fig. 3, in the following manner:

1. As a preliminary setting, turn needle out from its seat about 1 to $1/4$ turns open.
2. With engine warmed up and running at idle speed, crack throttle open suddenly.
3. If engine hesitates before speeding up, open Main Jet Needle $1/8$ to $1/4$ turn. Repeat until engine goes from idle to high speed without hesitation.

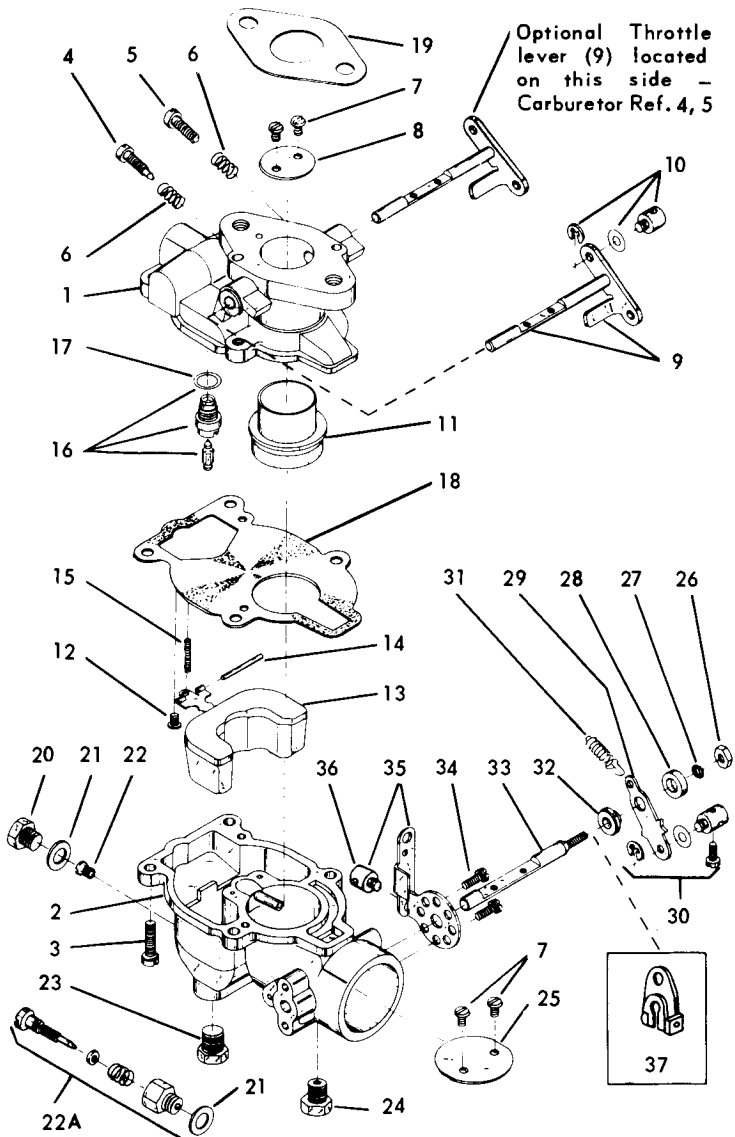

Fig. 3 EXPLODED VIEW
Instructions and Service Parts Illustration

CARBURETOR OPERATION, REPAIR and SERVICE INSTRUCTIONS

WISCONSIN No. **L 116**WALBRO No. **LMH-33**For Engine Model **W2-880**

OPERATION, Fig. 1

Fuel from supply tank flows to **float valve seat** (1), through **fuel valve** (2) and into **fuel bowl** (3). As the level in fuel bowl increases, the **float** (4) rises, shutting off fuel supply by forcing **fuel valve** (2) into seat. As fuel is being used, the float lowers and allows additional fuel to enter bowl through the fuel valve.

Fuel from the bowl enters the **main fuel jet** (5), then through and up to the **main nozzle** (7). At full throttle, fuel passes through **main nozzle** (7) where it is mixed with air from **nozzle air bleed** (8) and enters into **venturi** (9). At low idle speeds, fuel flows through the **idle jet** (10), up the **idle channel** (11), around **idle adjustment** (12) and into the **emulsion chamber** (13), where it is mixed with air entering the **idle air vent** (14). This air-fuel mixture then enters the throttle bore of carburetor through the outer **idle hole** (15). As the throttle is gradually opened, the inner hole starts to feed the throttle bore, and assists the **main nozzle** (7) in taking over the full throttle range.

When starting, the **choke valve** is closed and the **throttle valve** (16) is opened causing an abnormally high suction on both idle and main systems, thus providing a rich mixture for starting.

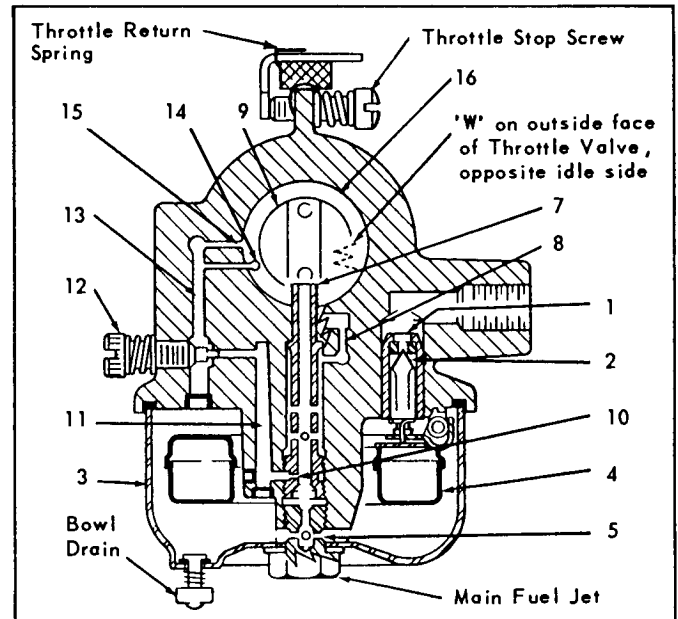

Fig. 1

CARBURETOR TROUBLES — CAUSES AND REMEDIES

Dirt is the major cause of field service carburetor problems. An adequate Fuel Filter must be used between the tank and carburetor, and should be serviced frequently. Service Air Filter daily — Keep carburetor and linkage free of dirt.

FUEL LEAKS FROM CARBURETOR

Float level set too high: Remove bowl, invert carburetor and set float .050 inch from casting rim. See Fig. 2 and Float Setting Instructions, page 38.

Dirt under inlet needle valve: Remove inlet valve, clean seat by rinsing in mild solvent or clean fuel, and blow off with compressed air.

Bowl vent plugged: Remove bowl and blow thru body vent hole with compressed air.

Collapsed float, caused by blowing assembled carburetor with compressed air: Replace float.

Carburetor gummed from storage - float stuck: Remove fuel bowl and clean.

ENGINE SMOKES AND RUNS RICH

Dirty air filter: Clean per instructions.

Improper adjustment: Set Idle Needle 1 turn open from seat. Refer to Adjustment Instructions, page 38.

Bowl retainer gasket leaks: Tighten securely, or replace.

Air bleed in carburetor plugged: Remove fuel bowl and idle needle. Clean thoroughly with compressed air.

ENGINE RUNS LEAN

Improper adjustment: Set Idle Needle 1 turn open from seat. Refer to Adjustment Instructions, page 38.

Idle holes plugged. Dirt in fuel delivery channels: Remove fuel bowl and idle needle. Clean thoroughly with compressed air.

Low fuel level: See Fig. 2 and Float Setting Instructions, page 38.

Fuel filter plugged: Remove and clean.

ENGINE STARTS HARD

Improper adjustment: Set Idle Needle 1 turn open from seat. Refer to Adjustment Instructions, page 38.

No fuel in carburetor: Check carburetor drain valve. Clean tank, filter and carburetor. Check fuel lines for obstructions, and test fuel pump.

Choke valve not closing: Check linkage for proper travel.

GOVERNOR SURGE

Governor sticking: Check linkage for binding.

Throttle shaft and valve binding: Remove and replace shaft if worn. Clean carburetor body and reassemble throttle shaft.

DISASSEMBLY

Before disassembling: Clean outside of carburetor from all foreign material.

CAUTION: When cleaning a completely assembled carburetor, **do not blow** with compressed air, you may collapse the float.

DO NOT soak or boil carburetor or body in chemical solutions. Idle channel is permanently sealed — solution will seep in and cause corrosion. Use a mild solvent, fuel oil or kerosene.

Disassemble parts in the following sequence: Refer to exploded view, page 38.

- | | | | |
|----------------------------|--------|------------------------------|------|
| 1. Main fuel jet | (4) | 10. Choke valve screws .. | (18) |
| 2. Retainer gasket | (5) | 11. Choke valve | (22) |
| 3. Fuel bowl | (2) | 12. Choke shaft | (19) |
| 4. Fuel bowl gasket | (3) | 13. Throttle valve screws . | (18) |
| 5. Float shaft | (7) | 14. Throttle valve | (17) |
| 6. Float and spring | (6, 8) | 15. Throttle shaft | (14) |
| 7. Fuel valve-spring | (9) | 16. Throttle shaft seal | (16) |
| 8. Idle needle assembly . | (11) | 17. Throttle return spring | (15) |
| 9. Throttle stop screw ... | (13) | | |

CAUTION: Do not remove nozzle (Ref. 10) from carburetor, unless replacing it with a **new service nozzle** — idle holes will not line up. Tighten 15 to 20 inch pounds torque. Use a proper fitted tool to prevent damage to slot in nozzle head.

Viton seat for fuel valve can be replaced if necessary. Pull out by means of a small hook on the end of a wire paper clip.

Clean throttle shaft seal in fuel oil or kerosene and dry. Re-oil with No. 30 weight oil or equivalent.

REASSEMBLY

Wash all other parts with carburetor cleaning solvent and blow off with compressed air.

Install choke shaft and valve. Mount valve with **part number** toward the outside with the valve in a closed position.

Mount throttle valve, with letter "W" on valve facing outward and opposite idle side of carburetor. Make certain valve plate does not bind when opening and closing throttle. Be sure that return spring tension holds throttle valve closed.

Viton fuel valve seat; press firmly in place with groove end toward seat hole.

Tighten **main fuel jet** (4), to 35 inch pounds torque.

FLOAT SETTING, Fig. 2

Mount all other parts in reverse order of disassembly. Hook fuel valve spring under float adjustment tab, and float support spring as illustrated in fig. 2. Float should be .030/.070 inch from top of body casting rim — bend adjustment tab to raise or lower fuel level.

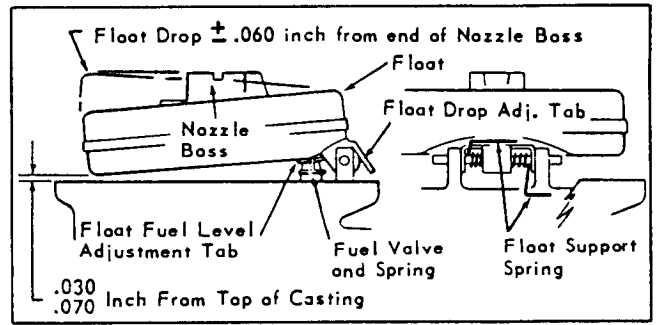

Fig. 2, FLOAT SETTING

ADJUSTMENTS, Fig. 3

Turn **Idle speed screw** (13) in, until throttle valve is slightly open. With engine warmed up and running, turn adjusting screw in or out as required to obtain desired low idle speed (1000 to 1200 r.p.m.).

The **Idle adjusting needle** (11) should be seated lightly (clockwise), then backed out **1 + 1/8 turns** as a preliminary setting. With engine warmed up and running at about 1200 R.P.M., fine tune idle mixture for smooth steady running.

The **Main Metering Jet** (4), for high speed operation is **fixed** (not adjustable).

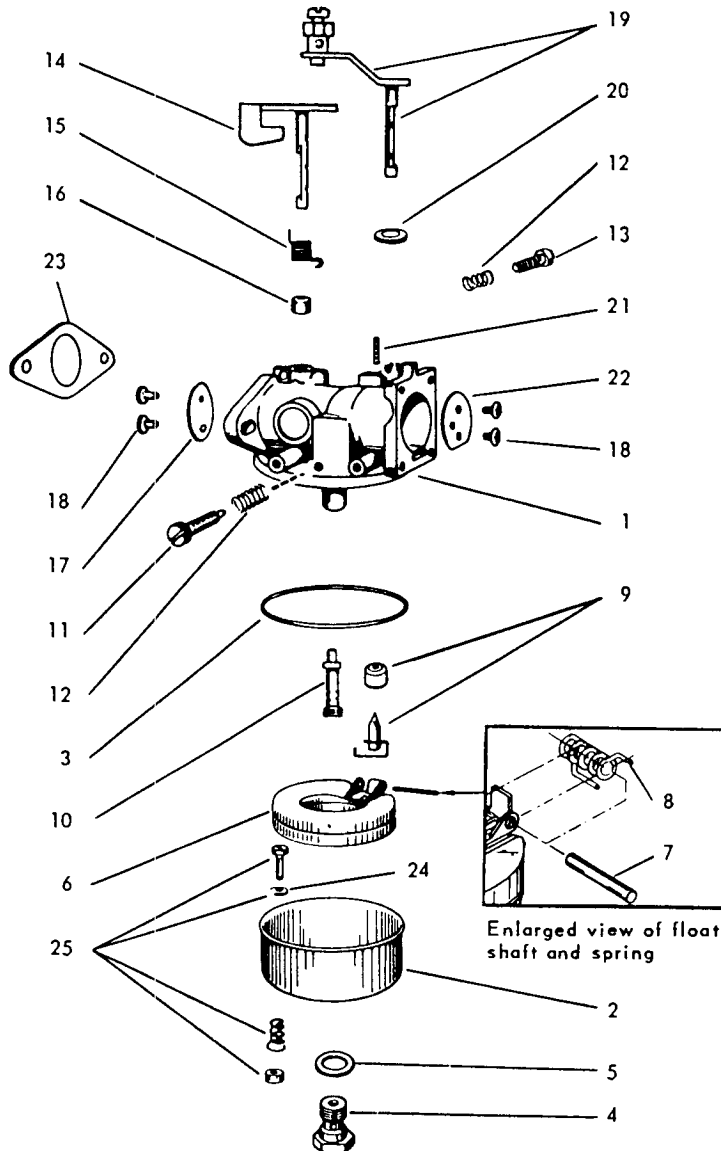

Fig. 3, EXPLODED VIEW

CARBURETOR SERVICE INFORMATION

WISCONSIN No. L 131-1

WALBRO No. WHG53

Engine Model W2-880

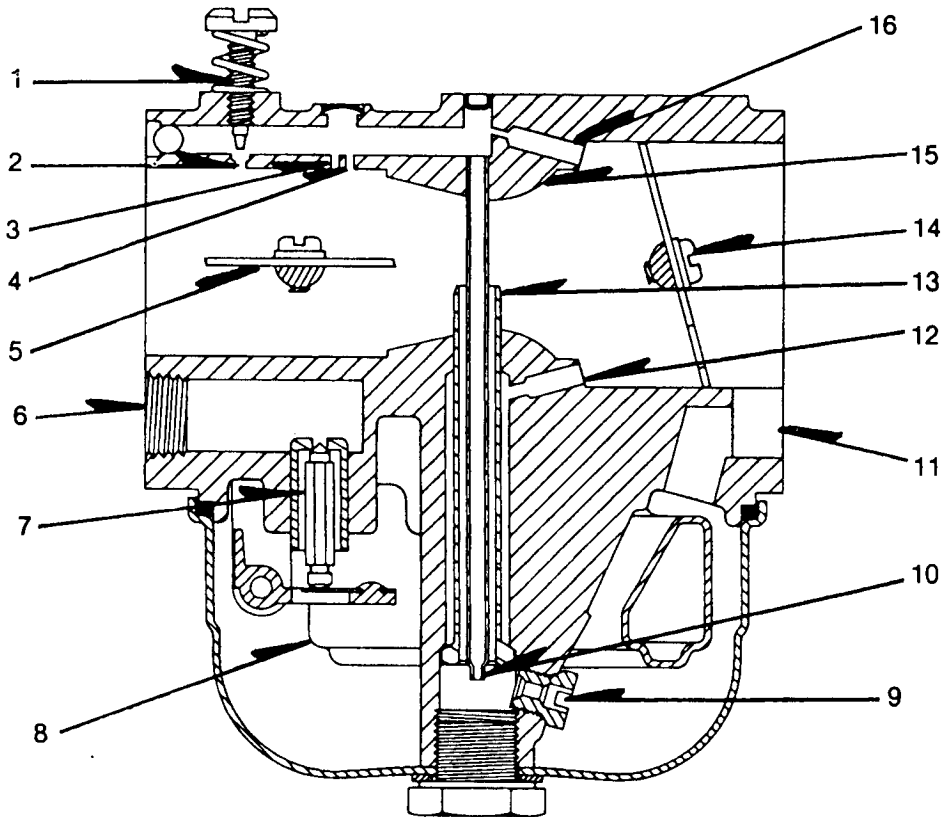

1. Idle Adjustment Needle: Adjust for correct amount of fuel delivered to the primary idle hole.
2. Primary Idle Hole: Main source of fuel to engine at the idle position.
3. First Progression Hole: Feeds air to primary idle hole at idle position and fuel thru progression.
4. Second Progression Hole: Feeds air to primary idle hole at idle position and fuel thru progression.
5. Throttle Valve Assembly: Regulates engine speed as it exposes idle holes and nozzle.
6. Fuel Inlet: Fuel from gas tank enters carburetor here.
7. Inlet Needle Valve: Meters amount of fuel allowed into bowl by way of float function.
8. Float: Maintains a constant fuel level in bowl.

9. Main Jet: Meters amount of fuel delivered to nozzle and idle system.
10. Idle Tube: Delivers fuel from bowl to idle progression holes.
11. Bowl Vent: Maintains atmospheric pressure on fuel in bowl.
12. Nozzle Well Vent: Meters air to the nozzle system.
13. Nozzle: Main source of fuel at the wide open throttle position.
14. Choke Valve Assembly: Closed at start position to allow manifold vac to draw only fuel from nozzle and idle holes.
15. Venturi: Velocity of air increases at this point to draw fuel from nozzle.
16. Idle Air Vent: Air enters here to create an emulsion of air and fuel at the idle position.

CARBURETOR SERVICE INFORMATION

WISCONSIN No. L 131-1

WALBRO No. WHG53

Engine Model W2-880

1. HARD STARTING

CAUSE

- (a) Improper idle needle adjustment
- (b) No fuel in carburetor
- (c) Choke not closing properly
- (d) Inlet needle stuck

REMEDY

- Carefully reseal idle needle and backout to 1¼ turns open. After engine starts and runs, set for optimum performance.
- Remove tank filter and carburetor. Clean thoroughly.
- Check choke control for proper travel.
- Remove and wipe clean, also clean inlet seat.

2. ENGINE RUNS RICH

CAUSE

- (a) Improper adjustment
- (b) Float level set too high
- (c) Inlet needle stuck
- (d) Float bowl gasket leaks
- (e) Air bleeds in carburetor plugged
- (f) Choke not open

REMEDY

- Carefully reseal idle needle and back out to 1¼ turns open. After engine starts and runs, set for optimum performance.
- With fuel bowl and carb inverted, set float.
- Remove needle and wipe clean. Also clean inlet seat and blow with compressed air.
- Remove and replace gasket.
- Remove idle needle and float bowl. Clean with compressed air.
- Inspect lever and linkage to insure proper opening.

3. ENGINE RUNS LEAN

CAUSE

- (a) Improper adjustment
- (b) Idle holes plugged and dirt in fuel delivery channels
- (c) Float level set too low
- (d) In-tank fuel filter plugged

REMEDY

- Carefully reseal idle needle and backout to 1¼ turns open. After engine starts and runs, set for optimum performance.
- Remove Welch plug, float bowl and idle needle. Clean thoroughly with compressed air. Be sure idle holes are open.
- With bowl removed and carburetor inverted, set float.
- Remove from tank and clean or replace.

4. FUEL LEAKS FROM CARBURETOR

CAUSE

- (a) Float level set too high
- (b) Carburetor gummed from storage or bad fuel

REMEDY

- With bowl removed and carburetor inverted, set float.
- Remove fuel bowl and clean.

WICO MODEL XH-2D MAGNETO

WICO No. XH-1961C (Replaces XH-1961), WIS. No. Y-67, For MODELS TE and TF ENGINE
WICO No. XH-2531C (Replaces XH-2531 and XH-1961C), WIS. No. Y-67-A, For MODELS TE, TF, TH ENGINE

SERVICE INSTRUCTIONS

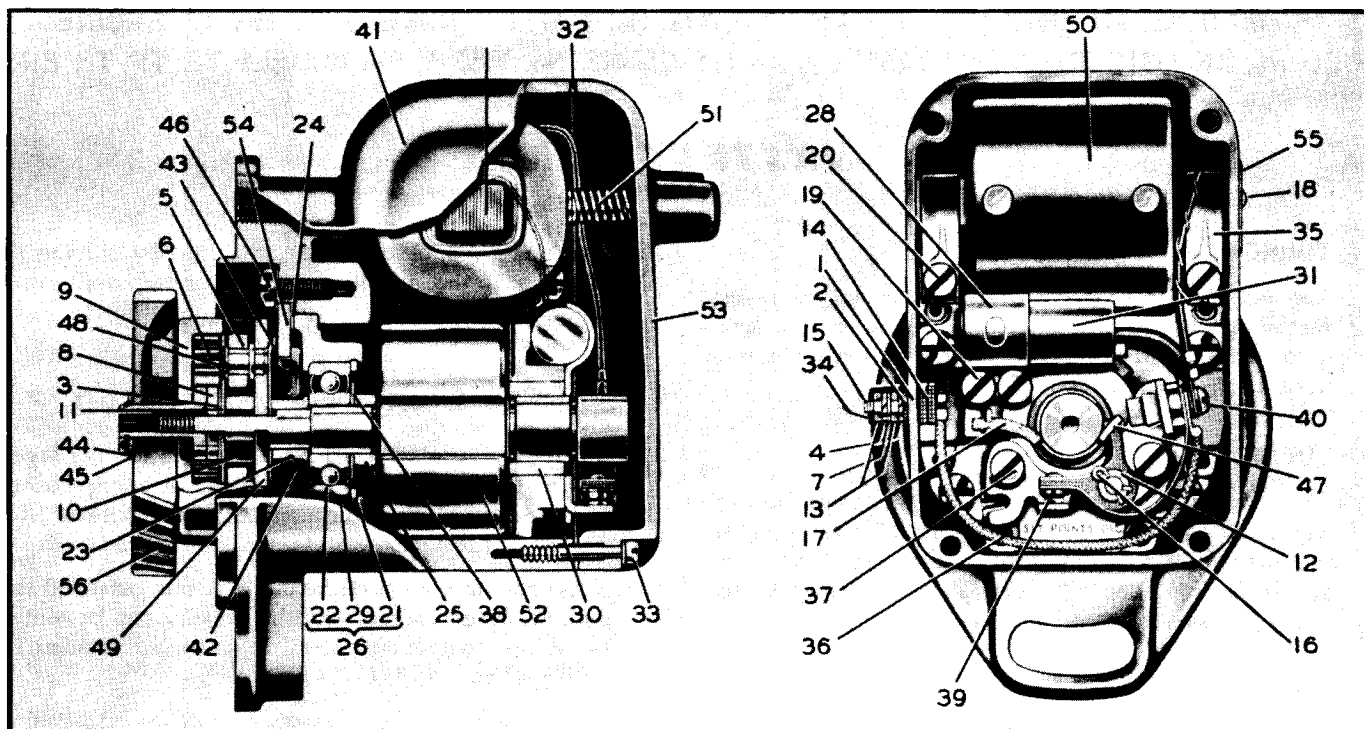

TIMING

The magneto is properly timed to the engine at the factory. If it becomes necessary to retune the magneto to the engine, refer to the diagram and instructions in the engine instruction book.

LUBRICATION

The only lubricating point in the magneto is the cam wiper felt (Ref. No. 17). This felt, which lubricates the breaker arm at point of contact with the cam, should be replaced whenever it is necessary to replace the breaker contacts.

IMPORTANT

Incorrectly adjusted spark plug gaps cause magneto failure more frequently than any other condition.

Spark plugs should be inspected at frequent intervals, the size of the gap should be carefully checked and adjusted and the plugs thoroughly cleaned.

All oil, grease, and dirt should frequently be wiped off the magneto, lead wires, and spark plug insulators. Keeping these parts clean and the spark plugs properly adjusted will improve the engine performance and at the same time will prolong the life of the magneto.

MAGNETO COVER

The magneto cover (Ref. No. 53) can be removed by loosening the four screws (Ref. No. 33) which hold it in place. When replacing the cover be sure that the cover gasket (Ref. No. 32) is in its proper place.

BREAKER CONTACTS — REPLACEMENT AND ADJUSTMENT

The breaker contacts should be adjusted to .015" when fully opened. To adjust the contacts, loosen the two clamp screws (Ref. No. 37) enough so that the contact plate can be moved.

Insert the end of a small screwdriver in the adjusting slot and open or

close the contacts by moving the plate until the opening is .015", measuring with a feeler gauge of that thickness, tighten the two clamp screws.

To replace the contacts remove the breaker spring clamp screw (Ref. No. 40), the breaker arm lock (Ref. No. 16) and washer (Ref. No. 12). Then lift the breaker arm from its pivot. Remove the aligning washer, 5717, and the two fixed contact clamp screws (Ref. No. 37). The breaker plate can then be removed.

If the contacts need replacing it is recommended that both the fixed contact and the breaker arm be replaced at the same time, using replacement breaker set X5996 (Ref. No. 39).

After assembly, the contacts should be adjusted as described above. The contacts should be kept clean at all times. Lacquer thinner is an ideal cleaner for this purpose. Use WICO tool S-5449, to adjust the alignment of the contacts so that both surfaces meet squarely.

CONDENSER

To remove the condenser (Ref. No. 31), first disconnect the condenser lead by removing the breaker arm spring screw (Ref. No. 40), then remove the two condenser clamp screws (Ref. No. 19), and the condenser clamp (Ref. No. 28). When replacing the condenser make sure it is properly placed and that the clamp screws are securely tightened.

COIL AND COIL CORE

The coil and coil core must be removed from the magneto housing as a unit. Disconnect the primary wire from the breaker arm spring terminal by removing screw (Ref. No. 40), take out the two coil core clamp screws (Ref. No. 20), and remove the clamps (Ref. No. 35). The coil and core can then be pulled from the housing. When replacing this group make sure that the bare primary wire is connected under the core clamp screw and that the insulated wire is connected to the breaker arm spring terminal.

MAGNETO SERVICE INSTRUCTIONS

Y-79B-S1 (FM-X2B7E) for Wisconsin Engine Model TJD

Y-79A-S1 (FM-X2B7D), replaced by Y-79B-S1

Y-79C-S1 (FM-X2B7F) for Schramm Compressor Engine VEF4

Y-79-S1 (FM-X2B7A), replaced by Y-79C-S1

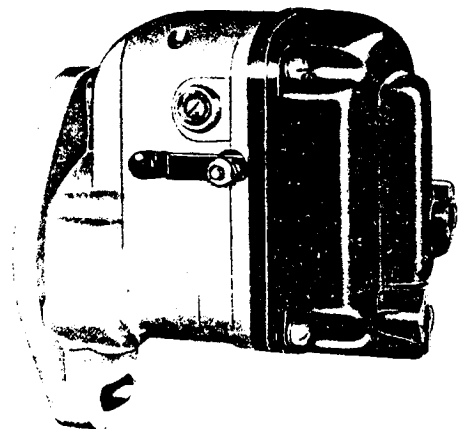

GENERAL DESCRIPTION

The type FMX2B7E magneto is adapted to the model TJD engines manufactured by Wis-Con Total Power Corp. The ignition spark is distributed to the engine spark plugs by the jump spark method. This magneto is flange mounted, clockwise in rotation and has a lag angle of 16° - 18° provided by an impulse coupling. The FMX2B7F magneto is used on the combination Wisconsin engine - Schramm compressor units.

SERVICE PROCEDURE

Improper functioning of the magneto is often believed to be the cause of engine difficulty arising from other sources, such as a flooded carburetor, insufficient fuel or air, loose ignition connections, or a defective spark plug. A brief engine inspection will often locate the trouble before the magneto is reached, and prevent maladjustment of parts in good condition. The magneto should be opened only when it is certain that the ignition spark produced is unsatisfactory. This condition may be determined by an ignition spark test, as explained in engine INSTRUCTION MANUAL.

SERVICING BREAKER POINTS, Fig. 1

Remove the magneto end cap and inspect the breaker points for evidence of pitting or pyramiding. A small tungsten file or fine stone should be used to resurface the points. Badly worn or pitted points should be replaced. If it is necessary to resurface or replace the breaker points, it will also be necessary to adjust them to their proper clearance which is 0.015 inch at full separation.

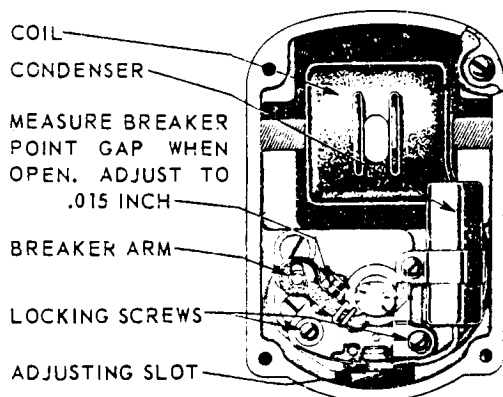

Fig. 1, BREAKER POINT ADJUSTMENT

The adjustment of breaker points is made in the following manner: Lightly loosen the two contact support locking screws, identified in Fig. 1. Then, with the points at full separation, move the contact support until the proper breaker point clearance is obtained. This is accomplished by means of a screw driver inserted in the slot at the bottom of the contact support and pivoted between the two small bosses on the bearing support. Lock assembly in place by tightening locking screws, and take a final measurement of breaker point gap after the locking screws are tightened. Finally clean the points with a piece of hard cardboard.

SEALING THE MAGNETO

Before replacing the end cap on the magneto frame, clean the contact surfaces between the end cap and frame. Coat the surface with gasket cement, place a new gasket in the joint, mount the end cap on the frame and securely tighten the four end cap screws.

FURTHER FIELD SERVICE NOT RECOMMENDED

The cam wick, if dry or hard, should be replaced by a new, factory impregnated, wick. Other than this the magneto does not require field lubrication and any attempt to oil or to grease the bearings is inadvisable. The lubricant should be renewed only during a complete overhaul of the magneto. Coil and condenser replacement, can be done if adequate test equipment is available.

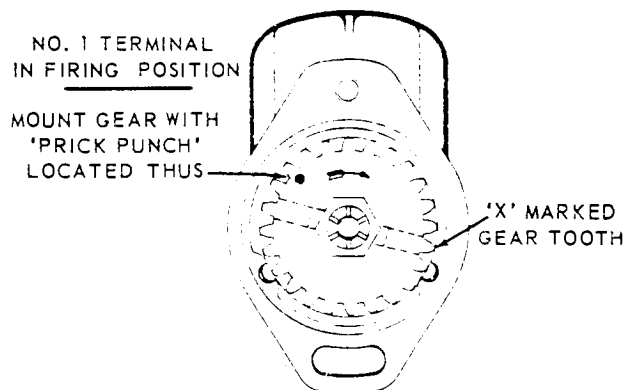

Fig. 2, DRIVE GEAR MARKING AND ASSEMBLY (for TJD)

DRIVE GEAR MOUNTING, Fig. 2

The magneto is equipped with a special drive gear mounted directly on the impulse coupling. If it is necessary to replace the drive gear, special care must be exercised in re-assembly. It is possible to be off 180° in timing if gear is improperly mounted.

Set magneto for spark discharge to the No. 1 terminal, (tower closest to engine). This is accomplished by inserting a short stiff length of wire into the No. 1 terminal socket and bend to within 1/8 inch of the magneto frame. Then turn the impulse coupling in a clockwise rotation, tripping the impulse, until a spark is observed between the wire and frame. Retain coupling in this position and mount gear with drive lugs in slot, and prick punch mark on gear face located as illustrated. The 'X' marked gear tooth will be located so as to be seen through gear cover inspection hole when magneto is mounted.

TIMING MAGNETO TO ENGINE

Ignition timing is accomplished by correctly mounting magneto to the gear cover. Refer to "MAGNETO TIMING" in engine INSTRUCTION MANUAL for assembly procedure.

MAGNETO SERVICE INSTRUCTIONS

(TYPE FM-X1-2B7-1)

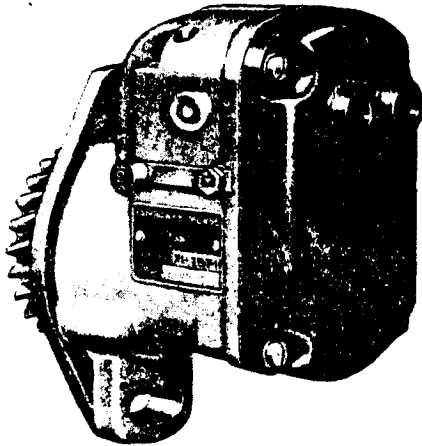

GENERAL DESCRIPTION

The type FM-X1-2B7-1 magneto is adapted to the models TE, TF TH and THD engines manufactured by Wis-Con Total Power Corp. The magneto is of a split-coil design in that there isn't any distributor, but instead two sparks are provided simultaneously every 360° of rotation. The magneto is flange mounted, clockwise in rotation and has a lag angle of 20° provided by a special impulse coupling.

SERVICE PROCEDURE

Improper functioning of the magneto is often believed to be the cause of engine difficulty arising from other sources, such as a flooded carburetor, insufficient fuel or air, loose ignition connections, or a defective spark plug. A brief engine inspection will often locate the trouble before the magneto is reached, and prevent maladjustment of parts in good condition. The magneto should be opened only when it is certain that the ignition spark produced is unsatisfactory. This condition may be determined by an ignition spark test, as explained in engine INSTRUCTION MANUAL.

SERVICING BREAKER POINTS

Remove the magneto end cap and inspect the breaker points for evidence of pitting or pyramiding. A small tungsten file or fine stone should be used to resurface the points. Badly worn or pitted points should be replaced. If it is necessary to resurface or replace the breaker points, it will also be necessary to adjust them to their proper clearance which is 0.015 inch at full separation.

The adjustment of breaker points is made in the following manner: Lightly loosen the two contact support locking screws, identified in Fig. 1. Then, with the points at full separation, move the contact support until the proper breaker point clearance is obtained. This is accomplished by means of a screwdriver inserted in the slot at the bottom of the contact support and pivoted between the two small bosses on the bearing support. Lock assembly in place by tightening locking screws, and take a final measurement of breaker point gap after the locking screws are tightened.

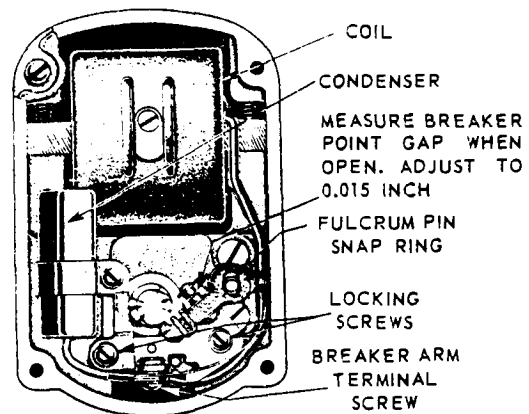

Fig. 1 END VIEW OF MAGNETO.

SEALING MAGNETO

Before replacing end cap on the magneto frame, clean the contact surfaces between cap and frame. Then coat the end cap contact surface with Fairbanks-Morse FMCO2 Gasket Varnish, place a new cork gasket in the joint, mount the end cap on the frame, and tighten the four screws securely.

FURTHER FIELD SERVICE NOT RECOMMENDED

The cam felt wick, if dry or hard, should be replaced by a new factory-impregnated wick. Other than this, magneto does not require field lubrication and any attempt to oil or grease the bearings is inadvisable. The lubricants should be renewed only during a complete overhaul of the magneto by a Factory-Authorized Magneto Service Center. Coil and condenser replacements, while simple, are not recommended unless test equipment is available.

TIMING MAGNETO TO ENGINE

Ignition timing is accomplished by correctly mounting magneto to the crankcase. Refer to 'MAGNETO TIMING' in engine INSTRUCTION MANUAL for assembly procedure.

W
2
-
8
8
8
-
0
8
8
8
-
T
J
D
-
T
H
D
-
T
H
H

SERVICE AND PARTS
Available from your Authorized
WIS-CON TOTAL POWER
Service Center

HEADQUARTERS:

3409 Democrat Road P.O. Box 181160 Memphis, Tennessee 38181
Phone: (901) 365-3600 TELEX: 462-1058 (ITT) FAX NO: (901) 369-4050

EUROPEAN:

Rue Joseph Deflandre, 13 B-4053 Chaudfontaine (Liege) Belgium
Phone: (32) (41) 675320 TELEX: 42631 TDY TP B FAX NO: (32) (41) 677987

TTP20123
JULY 1994